



# **Cedar Circle Farm Grower Food Safety Manual**

**Cedar Circle Farm Grower Food Safety Manual**

**Megan Baxter**

**Cedar Circle Farm**

**East Thetford, VT 05043**

***Index***

Mission Statement	2
Maps	3
General Information	4
Farm Review	5
Field Harvest	6
Processing Area	7
Storage and Transportation	8
Traceback Procedures	9
Appendixes	
A	10
B	11
C	12
D	13
E	14
F	15-22
G	23-26
H	27-32
I	33

## **Mission Statement**

One of the most important functions of Cedar Circle Farm is food safety. Both management and employees are committed to producing and marketing safe product safety through good agricultural practices that focus on principles of food safety and quality. To make sure our food safety goals are met, we have also designated Megan Baxter as supervisor to oversee the food safety program.

These safe practices include making sure there is no immediate safety risk present in areas where the produce is grown, processed, and packed and that there is no immediate risk of contamination of the product. We also make sure that insects, rodents, birds and pets pose no risk of contamination of our product. It is also a priority that all our employees follow healthy practices when working on the farm. We also make it our mission to present all information and paperwork pertaining to food safety in an efficient and truthful manner.

Maps

Processing Area

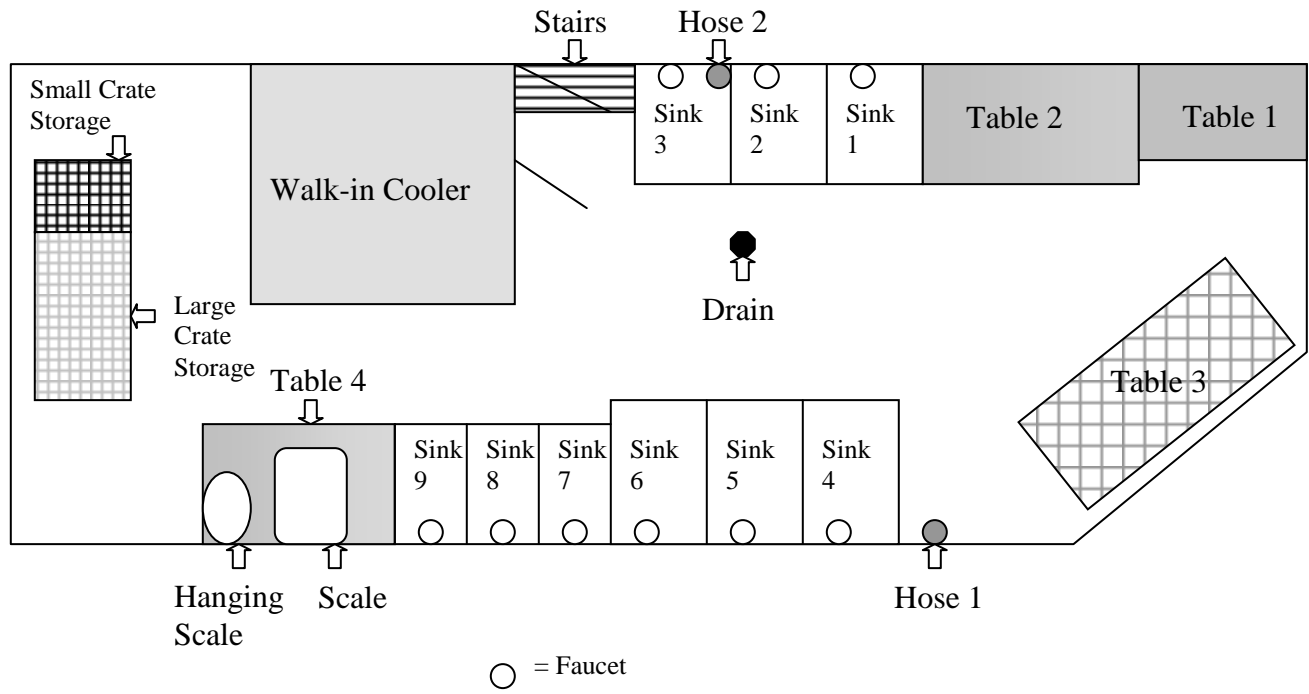

## **General Information**

Cedar Circle Farm has designated Megan Baxter as the supervisor to oversee and implement our food safety program. In case Megan Baxter is not available, Luke Joanis will serve as a back-up.

All employees of Cedar Circle Farm are trained and instructed on how to practice proper hygiene. Potable water is always available to all employees through the processing area and café. In order to make sure our employees receive adequate training, we provide small group instruction and demonstration on proper procedures (See Appendix A, B and C). We also require our employees to sign a policy agreement (Appendix D) We also post signs at all wash stations to make sure our employees are washing their hands.

We also make sure our restrooms are cleaned and maintained on a regular basis and properly stocked with toilet paper, single use paper towels and soap. Smoking and eating areas are separate from production and processing areas.

We have written emergency standard operating procedures (Appendix E).

## **Farm Review**

Cedar Circle farm uses river water as a main irrigation source in our fields. Our greenhouses and hoop-houses are irrigated from well water. Water testing is completed every two years. Our septic system is functioning properly and poses no risk to the fields. Our farm is also far away from any municipal sewage treatment facilities or landfills. We do not allow pets in our fields and in force this policy through signage and direct confrontation. Pest animals are controlled by trapping, hunting and sanitary measures. We follow all NOFA policies regarding the application of manure and bio-solids. The land has no history of contamination and has been open farmland for a hundred years.

## **Field Harvest**

Our farm makes sure all employees in the field take the necessary precautions to avoid contamination of the produce. In order to make this possible we have written harvesting standard operating procedures (Appendix F).

During harvest time, all harvesting containers and implements are cleaned before use. We have standard operating procedures if things such as petroleum, glass or blood contaminate our product.

The trucks and golf cars used at Cedar Circle Farm are kept clean and clear from dirt before harvesting and this cleaning is recorded (Appendix G). We also carefully load our produce to reduce damage.

## **Processing Area**

We have standard operating procedures for processing produce (Appendix H). Water used for all processes is potable as demonstrated by water sampling tests. The water temperature in sinks is also monitored on a regular basis and changed between crops. We clean and sanitize all water contact surfaces on a regular basis (Appendix I). At the end of the processing cycle, the processing area is thoroughly cleaned.

As mentioned in the previous section, our employees are trained and educated on worker hygiene. This includes break areas away from the processing area. We make sure that the processing area is clean and free from liter, debris and standing water. Our dumpster area is not located near the processing area.

Floor drains in the processing area are always watched and kept free from debris. We do not allow any animals, including pets, in the processing area.

## **Storage and Transportation**

All containers not being used are kept protected from contaminants. Containers being used for processed produce are always kept clean.

Our storage areas are kept in a clean and orderly manner. We ensure that our refrigeration areas are always clean and sanitary. We also monitor temperature on a regular basis with properly calibrated thermometers.

When transporting and loading our product, our employees make sure all equipment used for these processes are kept clean.

## **Traceback Procedures**

Cedar Circle Farm utilizes an efficient tracking system to track food items back to the source (our farm, by field number). Part of this is recording harvest dates, specific field and product locations, weight and spoilage. These records are kept in the Pick Sheet folder and also as a file on the management computer.

## **Appendix A**

### **Standard Operating Procedure: Sanitation**

**Workers have been instructed to carry out of the following general sanitation requirements:**

1. Smoking and eating take place in a designated area, away from where food is harvested, processed or stored.
2. Workers wear shoes/sandals at all times.
3. Vehicles used to transport produce must be kept clean on a regular basis, and this cleaning must be recorded.
4. Open wounds are immediately cared for and a fully stocked first aid kit is regularly maintained in the CC
5. Employees are instructed to exclusively make use of the porta-potties and bathrooms located on the farm.
6. All domestic animals are kept out of the fields
7. Pest populations are curbed through the use of sanitation, traps and hunting.
8. Hand washing and water bottle filling take place only in the hand washing sink. The wash sinks are for produce only.
9. Produce storage area (in the barn) must be swept out as necessary.

## **Appendix B**

### **Standard Operating Procedures: Orientation Training**

**During the first week of employees will participate in an orientation training session. At the completion of the session, all employees will be asked to sign a document, stating that Cedar Circle Farm's safety policies and SOPs have been explained to them, in a language in which they are fluent, in a clear and orderly manner. All questions or comments they might have had have been answered. It is the responsibility of the Policy Manager to perform these orientation sessions, collect signed contracts, and enforce policies throughout the year. During an orientation session the Policy Manager will:**

1. Give the employee a tour of the farm, familiarize employee with farm layout and location of bathrooms and hand washing stations
2. Demonstrate proper hand washing technique and describe when hand washing is required
3. Explain clothing and shoe policies (employees working in the farm stand may not go without shirts, field crew member must not wear clothing that will not hinder movement or present safety hazards around tractors, everyone must wear shoes or sandals at all times)
4. Show employee location of first aid kit and telephone in case of emergency
5. Go over emergency policies
6. Read out loud SOPs for sanitation and worker hygiene
7. Describe cleaning policies, explain chore sign up sheet and cleaning records
8. Answer all questions or comments
9. Ask employee if these policies have been made clear to them
10. State that these policies will be enforced throughout the year and that repeat failure to comply with these policies could result in termination of employment
11. Have employee sign and date contract
12. Place signed contract in appropriate binder.

## **Appendix C**

### **Standard Operating Procedure: Worker Hygiene**

**All workers will be trained in proper hand washing and sanitation techniques. Ample signage, regular monitoring, management leadership and refresher courses as needed will encourage hygiene.**

1. All workers must wear shoes or sandals
2. Employees must wash hands **after** using the restrooms, smoking, eating, touching hands or face, coughing or sneezing when handling produce. All employees must wash hands **before** handling produce or crates used for processing.
3. Employees must limit their consumption of food to designated areas, away from where food is processed or stored.
4. Employees may not smoke in an area where food is processed or stored.
5. Employees must work in clothing that is as clean as practical, all dirty or secondary articles of clothing must be stored in an area separate from where food is processed or stored.
6. Employees must use the restrooms and porta potties provided by the farm.
7. Employees may not store food, clothing, water bottles or any articles in crates that are used for processed or stored food.

**Appendix D**

**Cedar Circle Farm, East Thetford, VT 05043, 802-785-4737  
SEASONAL EMPLOYMENT POLICIES**

Cedar Circle Farm is a 40 acre, certified organic mixed vegetable and greenhouse operation in East Thetford, VT. All employees are required to read and sign this document.

Hours vary from week to week depending on weather and workload. A full time employee can expect to work 30-40 hrs a week. Overtime is allowed but pay remains the same. Scheduling will be set by management but may change on a daily basis depending on weather. Work is varied and you will most likely have multiple tasks throughout the day. Flexibility and efficiency are essential.

Come prepared to work in all weather. The only thing that keeps us out of the fields is lightning. Dress appropriately and bring a change of cloths everyday. We recommend that you wear cloths meant for farm work, things that you don't mind getting dirty and that allow you to move easily. You will need work or hiking boots, active wear sandals and mud boots. On warm days you will want a hat. You will also need good rainwear, including rain pants. Inappropriate clothing is clothing that prevents you from working. You will be provided with a cubby to store your cloths and other items in. These cubbies are in a public space and must be kept clean.

Lunch breaks are 1/2 hr and paid. There are several stores nearby but we recommend you bring lunch, as there are often long lines. Bring a large water bottle to work daily, or keep one in your cubby. It is important that you keep it with you at all times as it is easy to become dehydrated in the fields. Breaks will be called by management due to weather conditions and work load and will total no more than 1/2 hr. a day.

We cannot tolerate late arrival. A late employee will set the whole crew back. Each late arrival will warrant a conversation with the field manager. If this behavior occurs 3 times your employment will be terminated.

Employees are allowed 1 free coffee or tea drink every day. All other items must be paid for. Employees receive a 20% discount on all items in our farm stand and coffee shop. Culled produce will be set aside for employees. You may also harvest directly at the permission of the field manager.

Time off must be requested 2 weeks prior and presented in writing to the field manager. field manager ASAP.

Being under the influence of drugs or alcohol at work is not permitted. Smoking cigarettes is allowed during lunch or manager sanctioned breaks and only in designated areas.

We work hard to make Cedar Circle a safe and clean environment. You will be instructed in proper produce handling and sanitation techniques and are expected to comply to them at all times. You will often work near equipment or with blades. Use your common sense, listen to your manager's instructions and be aware at all times of your personal safety. Paying attention is the best way to avoid injury. Farm work is hard, physical labor. Take care of your body but expect to get a daily workout at the farm.

The first week of your employment is a training period. At the end of the week expect to meet with management to discuss your work. You have got to have a good attitude and want to be here. Please treat all staff respectfully.

If you have further questions please speak to Megan or Luke.

**By signing this document you are stating that you have read, understand and will comply with its contents.**

\_\_\_\_\_ (print name) \_\_\_\_\_ (sign name)

## **Appendix E**

### **Emergency Plans**

#### **Spillage of porta-potty**

1. Rope off area
2. Call porta-potty company
3. Spread absorbent
4. Remove contaminated soil

#### **Spillage of pesticides or fuel in field**

1. Rope off area
2. Spread absorbent
3. Remove contaminated soil

#### **Broken glass in PA or in harvesting fields**

1. Make sure workers are wearing shoes and gloves
2. Isolate hazardous area
3. Sweep/pick up visible glass/vacuum
4. Wash down sinks and sanitize
5. Remove contaminated soil if breakage occurs in the field

#### **Emergency medical situation**

1. Call 911
2. Notify Field or Farm Manager
3. If possible, move individual up to Pavillion Road

#### **Spillage of blood in PA or in harvesting**

1. Put on latex gloves
2. Isolate contaminated area
3. Absorb blood
4. Wash and sanitize area

## Appendix F

### Standard Operating Procedures: Harvesting

#### *COVER SHEET*

**Tools and Harvesting Containers:** Tools and harvesting containers are located in the barn, near the door from the PA. Tools hang on the wall closest to the PA and on the wall that divides the lower level of the barn. Harvesting containers are located in this area as well. Check tools and harvesting containers prior to entering fields. They should be clean of any visible residue. Harvesting tools should be sharp.

**Before Entering the Field:** Employees must wash hands. This is a good time to fill water bottles, put on sunscreen etc. Bring a raincoat or poncho into the field if rain is forecasted. Check the PA white board for your daily harvesting allotment. Gather the necessary tools, including rubber bands, knives and containers and place them in the back of a vehicle. Gather all the tools necessary for all harvesting jobs (example, knives for harvesting lettuce as well as bands and fork for bunching carrots) so that you will not have to return to the PA during harvesting hours. Remember exact harvesting numbers, if this is difficult, write them down on a slip of paper. If you have questions regarding a harvesting process consult this manual or speak to a manager.

**In the Field:** Make sure all necessary tools and containers are out of the vehicle before it moves away. Tasks should be assigned in the order of priority but a good rule to remember is that leafy greens should be harvesting earliest in the day, when the weather is coolest. Remember also that leafy greens must immediately be taken to the PA for processing to prevent wilting. Once in the field survey the crop. Is there ample produce for your harvesting allotment; will you need to take every plant or be selective? Is there damage to the crop that would prevent its harvesting? The best time for questions is before you begin. Speak to a manager if problems arise.

**Harvesting Efficiency:** The best pace is the point where speed and accuracy meet. It may take a few tries before you settle on a pace. Be aware of how fast others perform a certain job. If you have questions about how long a certain job is usually preformed, ask a manager. Everyone works differently but a good measure is heartbeat. If your heart is beating a resting rate you probably aren't working fast enough. You should not be rushing, but you should be in motion all the time. Here are some tips to working at the most efficient rate:

1. Place rubber bands around wrist or in an easy to reach pocket.
2. Bring harvest container with you as you move throughout the field, you should not be backtracking.
3. Stand up. This will allow you the widest range of motion and movement and will increase your rate of productivity.
4. Place a set amount of produce in each harvesting container. For instance, place 24 bunches of carrots, six bunches a layer, 4 layers to a container. This easy math

will help you keep track of where you are in the day and will prevent having to recount.

5. Keep an eye on the time (or the sun), try to calculate how long you are spending on each bunch, or fruit, ask yourself if you could work faster.

**Harvesting Policies:** The goal is to get the produce to the PA as quickly as possible. It should not sit out in the sun, or in the field.

1. Leave completed harvesting containers at the end of the row closest to a road.
2. Any driver of either golf carts or the red truck must stop (space permitting) to pick up completed harvesting containers.
3. If you are harvesting a particularly sensitive crop, or if it is a very hot day produce must reach PA more quickly than usual. All managers and other select employees wear radios and will most likely be working within earshot. Ask them, if they do not have a vehicle, to take your completed harvest container up to the PA.
4. If you need to reach the PA, or the farm stand area for any reason wait until there is a vehicle going in that direction, do not walk.
5. Work consistently. All bunches should be the same size etc. The goal is to sell a uniform product.
6. Be aware of damaged produce in the fields. Examine carefully the condition of what you are harvesting, don't ask, "Would I eat that?", ask "would I pay money for that?" Here are some things to look for that would render produce unfit for sale and harvesting:
  - a. Insect damage, especially excessive damage to leafy crops, or borage in root crops
  - b. Bolting, if a plant is going to seed or flowering (with the exception of dill) it is not harvestable
  - c. Excessive yellowing or wilting of leafy crops. Beets and carrots are still harvestable if their leaves are in bad shape, but they must be separated from the root in the field and sold without greens.
  - d. Splitting. This will occur often in heirloom tomatoes and radishes.
  - e. Signs of animal damage, most often found on squash and strawberries.
  - f. Wilting occurs most often with Swiss chard and beet greens.
  - g. Scrapes or scars, especially on summer squash and zucchini
  - h. Harvesting errors, snapped leaves,
  - i. cuts, knicks, lack of stem, overhandling

**General Requirements:**

1. If you sneeze, cough or touch your face, you must return to the PA to wash your hands. No exceptions.
2. Food and cigarettes are not allowed in the fields at any time during the harvesting process.
3. Shoes and appropriate clothing (rain jackets, gloves etc.) must be worn at all times.

## **Standard Operating Procedures: Harvesting**

**Artichokes-** Harvest when chokes are firm and tight, when bottom leaves just start to open, cut at 45° angle leaving 1-1/2 inch stem if possible. Harvest into orange baskets.

**Arugula-** Harvest loose in or in bunches. If harvesting loose use scissors to cut largest and healthiest leaves into tote. If harvesting bunches, cut whole tap root just below soil line and band into 1 inch diameter bunches, peeling off any yellowed or wilted leaf.

**Asparagus-** Cut 1 inch above ground or where stalk becomes woody. Check tip for blooming, do not harvest if wilted, frozen or shriveled. Harvest into green bags.

**Basil-** Harvest either by leaf or in bunches. For loose basil pinch or cut above next set of leaves. Do not harvest black, bolted or blemished leaves. For bunches cut stalk at base and band in 1 inch diameter bunches. Be sure to harvest only the cleanest basil and to use clean hands and containers, as basil will not be washed before sale.

**Beans-** Lift plant up and snap off ripe beans. Do not harvest small beans or overgrown beans. Do not over handle plants. Make sure to harvest the cleanest beans possible, to have clean hands and containers, as beans will not be washed before sale. Do not harvest one at a time, but harvest in handfuls in a sort of ‘milking’ motion, being careful not to break off the end of the beans. Harvest into bushel baskets.

**Beets-** Read size by size of leaves or by crowning shoulders. Select largest beets. Pinch off browned or wilting leaves. Band in bunches of 5 to 3, depending on size. Knock as much dirt off beets as possible. Harvest into totes, 24 bunches per tote.

**Beet Greens-** Harvest the smallest beets with the most vigorous and healthy looking greens. Pinch off browned or wilting leaves, avoid leaf spot or rusting on leaves. Band in 1-inch diameter bunches. The idea is to thin, leaving a healthy plant every 4 inches.

**Blueberries-** Do not harvest during rain or heavy dews. Harvest bright blue berries with no red or scarlet flush. Hold hand under bunch and strip bunch into bucket. Avoid under ripe, white berries, and ‘mummy berries’, which have shrunken. Try to leave as much white flush on the berry as possible. Empty buckets into pint containers on a tray, which holds 15 pints. Cull any underripe, overripe or mummy berries. Be sure to pick out any leaves or twigs that might have gotten into the berries.

**Broccoli-** Using brown knife cut head of broccoli leaving a couple inches of stalk. Cut only heads with tight clusters, avoid those that are bolting, loose or damaged. Cut away any leaves on stem. Harvest into orange baskets.

**Brussels Sprouts-** Either harvest by sprout or by stalk. Select firm, tight sprouts to break off in a downward motion from stalk. If harvesting stalk, cut with clippers at base, use knife to trim excess branches and leaves. Try to make uniform stalks. Cut away any diseased or overripe sprouts. Harvest into orange baskets.

**Cabbage-** Select firm, tight heads without damage. Pull head to one side and cut close to the base. Cut away excess leaves, leaving a few layers of outer protective leaves to prevent bruising while processing and shipping. Cut stem near flush to base. Harvest into totes.

**Cantaloupe-** harvest when cantaloupes are entirely brownish gold with no green showing through netting. Harvest when fruit slips off the vine easily. Harvest into the back of a truck or into orange baskets.

**Carrots-** either harvest entire row or select for largest carrots judging by thickness of green tops and crowning shoulders. For individual harvesting rotate carrot while pulling upwards. Use carrot fork approximately 6 inches from roots to prevent snapping. Band in bunches of 10, with band at shoulder. Collect all small or malformed carrots for bagging, leaving tops in the field. Knock as much soil off in field as possible. Leave all carrots showing signs of disease in field. Harvest into totes, 24 to a tote.

**Cauliflower-** cut with brown knife, leaving a couple inches of stem. Harvest largest, tightest heads that do not display any browning, yellowing or bolting. Cut away any leaves on stem. Harvest into orange baskets.

**Celeriac-** Pull up largest plants. Cut off leaves. Use brown knife to cut off largest roots. Tap off as much dirt as possible. Place in orange baskets.

**Celery-** Using brown knife cut below plant. Sever taproot. Peel off browned, or damaged stalks. Trim root back so that the cut is clean. Place in harvesting tote.

**Cherry Tomatoes-** Make sure hands are clean and dry before harvesting cherry tomatoes. Roll fruit off the branch; remove calyx and place gently into a container. Do not harvest one at a time, but rather in bunches. Avoid rough handling and try to leave all split fruit in the greenhouse or field. Harvest into pints on blueberry trays.

**Cilantro-** harvest either loose or in bunches. Cut just below soil line using scissors and keep clean of weeds. Bunch into one-inch diameter bunches. Immediately take to a cool or shady place as wilting occurs quickly.

**Cucumbers-** Do not pick up, move or shift plants, only move leaves so as not to break tendrils. Ripe slicing cucumbers should be 6-10 inches long, evenly shaped and 1 ½ -2 inches in diameter. Ripe pickling cucumbers should still retain their prickly spines but should be about 3-5 inches long and evenly shaped. Neither should show signs of yellowing, mold or cuts. Cut vine above cucumber with scissors, taking care not to snap stem off cucumber and place in tote. Remove all oversized cucumbers from vine and place in blank row or in cull container as instructed. Fill container to approximately 40lbs.

**Collards-** harvest either in baby or adolescent age as loose leaf or bunch as adult with 8 leaves to a bunch. Snap off leaf from plant at stalk in a downwards motion and bunch, with each leaf facing forward. Do not harvest leaves that show signs of yellowing or insect infestation. Immediately place bunches in shade.

**Corn-** harvest early in the morning for maximum sugar content. Ears should be firm and filled out, silk should be dry and brown and husk should show no evidence of insect infestation. Snap corn off stalk, downwards then upwards, being careful not to bring down stalk. Snap excess foliage off the bottom of the husk. Harvest into blue bags and dump into orange baskets, approximately 60 ears to a bushel.

**Dill-** harvest loose or in one inch bunches. Cut above ground line before plants begin to flower, or cut around bolted plants for fresh stalks. Immediately bring to shade.

**Eggplant-** Make sure hands are clean, as eggplant will not be washed before sale. Harvest when globes are heavy and shiny, Italian varieties should be pear-shaped, oriental varieties should be uniform and firm. Lift up foliage to find eggplant Cut with strong scissors or clippers above fruit. Avoid eggplants that show signs of yellowing, animal bites, insect infestations, mold, or cuts in the flesh. Cull these eggplants and place them in a blank row. Harvest into totes, no more than 2 layers deep to avoid punctures.

**Endive-** Harvest whole heads by pulling head aside, cut off root stalk close as close to the head as possible, knocking off any extra dirt in the field.

**Fennel-** use lettuce knife or sharp harvesting knife to cut away at root below bulb. Pull bulb to one side and cut. Trim roots off with knife in field then cut away branches in a diagonal style, leaving the longest stalks at the center 12-18 inches and the shortest stalks on the sides 8-10 inches. Harvest with lettuce knife into totes, 24 heads per tote.

**Garlic-** harvest when 3/5 or 5/7 of leaves are dry and yellowed. Harvest during a period of dry weather using sling to collect in bunches of 10. Knock off excess dirt by hitting bulb against the legs or palm of the hand in a gentle but thorough manner, be careful not to bruise the garlic. Harvest into orange baskets

**Garlic Scapes-** harvest loose in the field then bunch during processing. Cut when scape as turned 360 degrees and flower is pointing upwards. Snap off above the top leaf. Do not allow any garlic to go to seed, cut scapes thoroughly.

**Kale-** harvest loose in baby or adolescent stage or in one-inch diameter bunches in adult stage. Snap leaf off from stalk in downward motion. Avoid leaves that are browning, yellowing or show signs of insect infestation. Place bunches leaves front to back in a consistent and pleasing manner.

**Leeks-** Select largest leeks for harvesting, the thicker the better. Use fork to loosen soil. Cut off roots, making sure to not cut the leek itself. Peel off dead or rotten outer leaves. Collect in bunches of 3-5, depending on size. Hold bunch and cut leaves in a diagonal

manner so that they are longest in the middle (10 inches) and shortest at the sides (5 inches). Use brown harvesting knife to cut leaves.

**Lettuce-** Select the largest heads in the field for harvest. Check heads for signs of bolting and bottom rot. Cut heads as close to lettuce as possible. Peel off damaged or yellowed leaves, trim root stalk. Harvest using lettuce knife.

**Muskmelon-** Harvest when melons have turned from green to bright white. Roll off vine. Wipe off excess dirt in field. Check for soft, overripe spots, pinholes. Harvest directly in clean truck bed.

**Mustard Greens-** harvest either loose or in one-inch diameter bunches. Cut at base, being careful to avoid browned or yellow leaves. Use scissors to cut. Harvest into totes with 24 bunches per tote.

**Okra-** harvest okra that is no larger than two inches long and no smaller than one inch long. Cut stem with scissors. Wear gloves when harvesting okra because toxins on the plant cause rashes. Snap off leaves below harvest point. Harvest into bushel baskets.

**Onions, cured-** Harvest when neck breaks over. Pull up onions, tapping off excess dirt but being careful not to bruise onion. Harvest into blue bags, then dump into orange baskets.

**Onions, uncured-** Select largest onions for harvest. Pull up onions and cut off roots. Cut off any browned or wilted leaves with scissors. Peel off outer layers of onion skins that are dirty or flaking. Collect in bunches of 3-5s. Cut off leaf tops. Harvest into totes.

**Parsley-** harvest in one-inch diameter bunches. Cut individual stalks and bunch using scissors. Immediately take into shade.

**Parsnips-** Fork up parsnips, knock off excess dirt and bunch above shoulder, 3-5 in a bunch depending on size. Harvest into a tote with 24 to a tote.

**Peas-** Select peas of harvest depending on fullness, or size by variety. Roll off vine, being careful not to tear down the vine and break off calyx. Make sure hands and container are very clean as peas will not be washed before sale. Harvest into half-bushel baskets.

**Pea Tendrils-** Cut loose, taking only the first top four inches, the most tender part using scissors. Harvest into bushel baskets.

**Peppers-** harvest depending on color, or size, by variety. Check peppers for sunburn, rot or animal signs. Leave all damaged fruit in the field. Do not break off stem from fruit. Harvest into blue bags and dump into orange baskets.

**Potatoes-** Harvest either by hand or with tractor. If harvesting by hand pull up dead plant and dig around root system, being careful not to nick potato with fingernails. Pull up

potatoes and place in container. If harvesting behind tractor pick up potatoes that lie on the surface and dig underneath the surface for others. Place in container. In both cases try to leave as much dirt in the field as possible while keeping the potato skin intact.

**Potatoes, New**-Pull up green plant and dig around root system for potatoes. Be very careful not to break or damage the skin. Try to leave as much dirt in the field as possible. Place in container. Do not throw or bruise potatoes.

**Pumpkin**- Cut pumpkins before harvesting, when they are ½ green. Cut the longest stem possible. Rub off any excess dirt in field. Harvest to truck or bin with pruners.

**Radishes**-Harvest in bunches of 8-10. Select largest, thinning the row. Knock off excess dirt in field. Pick off browned or yellowed cotyledon leaves. Watch for splits and irregularities. Harvest into totes, 24 bunches per tote.

**Raspberries**- Harvest as late in the day as possible, when there is little dew on the berries. Be extremely careful when harvesting and select berries that are almost ripe, or will be ripe in the next day. Do not pick rotten or damaged berries. Harvest into ½ pint containers onto a blueberry tray.

**Rhubarb**- Cut thickest, reddest stalks at base. Cut off leaves. Harvest into totes.

**Rutabaga**- Pull up rutabaga, cut off foliage at shoulder and tap off excess dirt from rootstalk, cut off excess roots using brown harvest knife into orange baskets

**Salad Mix**- Harvest into black crate using scissors. Carefully cut above cotyledons in hand size bunches. Brush off bottoms of stems to get rid of any cut, damaged, yellowed or wilted leaves.

**Scallions**- Fork up scallions. Collect in bunches of 5-10, approximately one inch in diameter. Cut off top of leaves then cut off roots. Harvest into totes.

**Spinach**- Cut either as baby spinach in its young stage or as bunched spinach when mature. For baby spinach cut or pinch above lowest set of leaves, selecting only the best looking leaves. For bunched spinach cut taproot underground with scissors, peel off any yellowed, wilting or otherwise damaged leaves. Collect in ample bunches and band. For full size bulk spinach pinch off outer leaves, but not those that are arrowed or bolted.

**Summer Squash & Zucchini**-Harvest when 5-8 inches in length and consistent in width. Harvest paddy-pan squash when 3-4 inches in diameter. Cut squash from plant using red knife, making sure to avoid nicking the fruit. Lift out of plant, taking care not to brush spiney leaves which will scar the fruit. Cull any overgrown or damaged fruit into the blank row or into cull container as instructed. Harvest into totes of approximately 40 lbs.

**Strawberries**-Harvest when ripe according to variety. Harvest on knees so that you can see the berries best, look under leaves and in row for heavy clusters. Do not pick under

ripe or damaged fruit. Leave cap on when harvesting and stem if harvesting Eros. Avoid molding, catfacing or rotten berries. Quarts should be filled with red, completely ripe berries free of any sign of disease or animal/insect marks. Caps should be on and facing downwards, so that the top of the quart appears completely red. Quarts should be overflowing. Place quarts behind you in the row to be collected into flats holding 15 quarts.

**Tomatillos-** Harvest tomatillos when firm and full within husk. Check plant from the growing point up for all full husks. Harvest into ½ bushel baskets.

**Tomatoes-** Harvest when fully ripened, depending on color and size. Tomato should give way to light pressure but should not be soft. Avoid tomatoes that show signs of disease, sunburn or animal marks. Pluck off stem. Make sure hands and container are clean before harvesting, as the fruit will not be washed before sale. Harvest into little black crates, in a single layer whenever possible.

**Turnips-** Harvest either as greens or in root bunches. When harvesting green select healthiest foliage, peel off leaves that show signs of yellow or insect infestation. Collect into one-inch diameter bunches. For roots, pull largest turnips knock off excess dirt and collect in bunches of 3-5.

**Watermelon-** Check melons daily for three signs of ripeness: the tendril leaf is either wither and brown or has fallen off, the yellow spot on the bottom of the melon has become darker in color and bruised, when tapped, the melon sounds hollow and heavy, like a drum. Roll melons off vine and wipe off dirt. Be careful not to break off stem. Harvest directly into truck, wagon or cart.

**Winter Squash-** Harvest when ripe depending on variety. Cut stalk from fruit, dust off excess dirt in the field. Leave 1 inch stem. Harvest into baskets or bins.

**Appendix G**

**Red Truck Cleaning Record**

**Tools should be removed, cleaned and returned to storage. Empty bed as well as any tools in cap. Sweep bed.**

<b>Date</b>	<b>Check</b>	<b>Date</b>	<b>Check</b>	<b>Date</b>	<b>Check</b>
-------------	--------------	-------------	--------------	-------------	--------------

**Market Van Cleaning Record**

**Van should be clean before transporting produce. Empty all trash.**

**Date    Check**

**Date    Check**

**Date    Check**

**White Golf Cart Cleaning Record**

**Tools should be removed, cleaned and returned to storage. Back and front pockets should be emptied, and everything put back where it belongs.**

**Date    Check                      Date    Check                      Date    Check**

**GI Slow Cleaning Record**

**Tools should be removed, cleaned and returned to storage. Back and front pockets should be emptied, and everything put back where it belongs.**

**Date    Check**

**Date    Check**

**Date    Check**

## Appendix H

### Standard Operating Procedures: Processing

#### *Cover Sheet*

##### **General Concerns:**

1. Sinks and all counters must be clean and dry prior to processing.
2. Water in sinks must be changed when it reaches 60 degrees or with each crop.
3. No crates should touch the ground.
4. Wash hands regularly and especially between crops, after using the bathroom, coughing or sneezing. Eating or smoking is not allowed during or near the PA.

##### **Processing Process:**

1. Two or more people will be assigned to processing. One of them will be designated a lead. They are responsible for checking off the day's cleaning list and for generally overseeing the entire process.
2. Make sure the PA is well lit, turn on lights as necessary.
3. Inspect PA for cleanliness, wash counters and clean sinks if there is visible residue.
4. Inspect cooler, clean as necessary, bring CSA baskets to stand etc.
5. Inspect picking allotments; pick sheets, order forms and CSA list. If there is an item that is new to you, consult this manual or ask a manager prior to processing.
6. Fill sinks to fill line.
7. Prioritize processing. Leafy greens must be processed first to prevent wilting. Harder items, like summer squash or cucumbers, can stand the wait.
8. Spray off produce at spraying stand.
9. Place produce in first sink with a gentle dunking motion. Allow to sit for an average of 5 minutes.
10. Move produce, with a gentle dunking motion to second sink. Wait 3 minutes.
11. Move produce, with a gentle dunking motion to third sink. Wait 2 minutes.
12. Compost any damaged or undesirable produce at this point.
13. Place produce in black crates in an logical and consistent manner (i.e. 24 bunches of carrots per crate, 40 lbs of squash)
14. Select best quality produce for sale in the stand or at market. This includes: the best sized summer squash, zucs and cucs, the nicest bunches of greens, the largest beets etc.
15. Weigh items or get a final count on the harvest, if they do not meet the day's requirements radio a manager immediately.
16. Mark final numbers in pick sheet, according to destination.
17. Immediately place items in PA cooler if harvested for markets, wholesale or CSA. If harvested for the stand bring immediately and place in cooler, do not let produce sit out, or assume anyone else will put it in the cooler for you.

18. Place items in cooler in an orderly and logical manner, for instance, CSA items on one side, wholesale items on the other. If there is any possibility of confusion, place a slip of paper on the top of the crate in question.
19. Empty sinks between each crop.
20. Refer to cleaning checklist when processing is complete.

### **Standard Operating Procedures: Processing**

**Artichokes-** Count and place in crates for storage in cooler at 40°F.

**Arugula-** If cut loose place in first sink, move to second and third sinks when appropriate then spin dry in orange spinner bunches of 2-3 handfuls per load, 25 rotations per load. If bulk 6-8 handfuls placed to drip-dry in crate. If cut in bunches, spray off roots, place in first sink then move to second and third sink when appropriate. Place in cooler at 40°F.

**Asparagus-** Store with base of asparagus on ice. Never keep over night, as sugar will have turned to starch.

**Basil-** Keep basil out of direct sunlight. Place base in water or bring loose basil to the stand or bakery for bagging or processing. Do not refrigerate unless very well insulated.

**Beans-** Keep out of sun, take beans to stand for sale after weighing and recording in picksheet.

**Beets-** Spray off beets to get most dirt off root before dunking in first sink. Move to second and third sink until clean. Place in crates then in cooler at 40°F with 12 bunches to a crate.

**Beet Greens-** Spray off beets to get all dirt from root before soaking in first sink. Move to second and third sink until clean. Place in crates then in cooler at 40°F, up to 24 bunches a crate.

**Blueberries-** Cool immediately, keep in shade when in the berry patch. Net pints to prevent spillage.

**Broccoli-** Place in cooler at 40°F.

**Brussels Sprouts-** Spray off sprouts and stalks. Place in cooler at 40°F.

**Cabbage-** Spray off or dunk in one sink. Place in cooler at 40°F.

**Cantaloupe-** Brush off as much dirt as possible with rag before bringing to stand for sale.

**Carrots-** Spray off carrots to get all the dirt from them as possible. Place in first sink, then move to second and third sink when appropriate. Place in cooler at 40°F in crates containing 12 bunches.

**Celeriac-** Spray off or dunk in one sink. Place in cooler at 40°F.

**Celery-** Spray off roots. Place in first sink, moving to second and third sink when appropriate. Place in cooler at 40°F.

**Cherry Tomatoes-** Net pints and half pints, make sure that they are filled to overflowing. Do not refrigerate.

**Cilantro-** Triple wash if harvested in bunches. If harvested loose, triple wash then place in orange spinner, approximately 25 spins needed to dry, then place in a clean crate and bring to the stand for bagging.

**Cucumbers-** Sort by variety and size bringing the best looking cucumbers to the stand or market. Spray off. Fill crates to approximately 40 lbs. Place in cooler at 40°F.

**Collards-** Place in first sink, move to second and third sink when appropriate. Immediately put in cooler at 40°F. 12 bunches to a crate

**Corn-** Bring to stand or keep in shade as much as possible.

**Dill-** Place base of bunches in water or bring loose dill to the bakery immediately for processing.

**Dry Beans-** Once beans have been combined bag or bottle clean product. Make sure hands are clean as well as containers as beans will not be washed before sale.

**Eggplant-** Sort by size and quality, spray off do not refrigerate.

**Endive-** Pick off any damaged or yellow leaves. Place in first sink, then move to second and third sink when appropriate. Place in cooler at 40°F. 12-24 to a crate depending on size.

**Fennel-** Break off rusted bulbage and trim stem. Spray off or dunk in first sink. Place in cooler at 40°F. 24 to a crate.

**Garlic-** Hang in barn until dry. Cut off roots and stem leaving 1 ½ inches, brush off first layers of skin until the bulb appears clean and white. Cull all bulbs that show signs of rot or mold and grade into 3 sizes: seed, retail and processing. Store in crates in the barn.

**Garlic Scapes-** Dunk in first sink and place in cooler at 40°F in a crate.

**Kale-** Place in first sink then move to second and third sink when appropriate. If kale has been picked loose spin in orange spinner, approximately 25 rotations until dry, otherwise drip dry. Place in cooler at 40°F. 9-12 bunches a crate.

**Leeks-** Spray off roots. Place in first sink, then move to second and third coolers when appropriate. Put in cooler at 40°F. 12 bunches per crate.

**Lettuce-** Peel off any yellow or wilted leaves, chop off any excess taproot. Place in first sink then move to second and third sink when appropriate. Place in cooler at 40°F. 12-24 per crate depending on size.

**Muskmelon-** Rub off excess dirt then bring to stand.

**Mustard Greens-**Place in first sink, move to second and third sink when appropriate. If harvest loose in young stage spin in orange spinner until dry, approximately 25 rotations. Otherwise, drip dry. Must be place on ice if stored for more than 2 days. Put in cooler at 40°F. 9-12 bunches per crate.

**Okra-** Keep out of the sun. Place in cooler at 40°F.

**Onions, cured-** when dry cut off roots and stem leaving 1 ½ inches and the bend. Sort by large and small sizes. Peel off outer-most layers of skin so that onion is clean. Cull any rotten, cut, molded bulbs or juicy stems. Store in the barn in wax boxes.

**Onions, uncured-** Spray off roots. Place in first sink, then move to second and third sink when appropriate. Place in cooler.

**Parsley-** Place in first sink. Move to second and third sink when appropriate. Place in cooler with base in water at 40°F.

**Parsnips-** cut off any wilted or browned leaves. Spray off roots. Place in first sink, then move to second and third sink when appropriate. Place in cooler at 40°F. 12 to a crate.

**Peas-** Place peas in shade. Weigh in PA. Bring to stand for sale.

**Pea Tendrils-** Place in first sink, then move to second and third sinks when appropriate. Place 2 handfuls into orange spinner and spin 25 to dry. Place in crates and then in cooler at 40°F.

**Peppers-** Spray off and dunk once. Place in crates, in only two layers. Place in cooler at 40°F.

**Potatoes-** Dunk in first sink. Stir water to float off seed potatoes. Cull any rotten or split potatoes. Allow to air dry before bringing to the stand or packing.

**Potatoes, New-** Separate one bushel into three crates. Place on counter. Very carefully spray top and bottom of crate, making sure not to break the skin, until potatoes are clean. If skin is too delicate, place in first sink then move to second and third sink when appropriate. Cull any rotten or split potatoes. Allow to dry before bringing to the stand or packing.

**Pumpkin-** Rub off excess dirt. Make sure to only sell pumpkins with the handle still attached.

**Radishes-** Spray off roots. Place in first sink. Move to second and third sink when appropriate. Place in cooler at 40°F. 24 to a crate.

**Raspberries-** Net pints or half pints. Place in the barn, covered with cloth. Sell only berries that have been picked that day or the day before.

**Rhubarb-** Place in first sink. Move to second and third sink when appropriate. Put in cooler at 40°F.

**Rutabaga-** Spray off root. Place in first sink. Move to second and third sinks when appropriate. Store in cooler at 40°F. Crates should weigh approximately 40 lbs.

**Salad Mix-** Place in first sink. Mix greens and lettuces together in water. Move to second and third sink when appropriate. Spin dry in orange spinner, 2-3 handfuls per load, approximately 25 spins. Pack in ½ lb bags, folded at the top. Put in cooler at 40°F.

**Scallions-** Spray off roots. Place in first sink, move to second and third sink when appropriate. Put in cooler at 40°F.

**Spinach-** If cut loose and baby place in first sink, move to second and third sinks when appropriate then spin dry in orange spinner bunches of 2-3 handfuls per load, 25 rotations per load. If bulk 6-8 handfuls placed to drip-dry in crate. If cut in bunches, spray off roots, place in first sink then move to second and third sink when appropriate. Place in cooler at 40°F.

**Summer Squash & Zucchini-** Spray off . Best quality squash always goes to farmstand or farmers market. Sort by variety and size. Place in cooler at 40°F.

**Strawberries-** Store in a cool, dry place away from insects and rodents. Only sell berries picked that day. Bring second day berries to the bakery for processing. Scan all quarts before sale for dirty berries or mold. Berry should all be facing up. No white or practically ripe berries should be in the quart, neither should berries that display cat facing or any other sign of disease. Quarts should be filled to overflowing.

**Tomatillos-** Place in cooler at 40°F.

**Tomatoes-** Weigh out tomatoes. Store in a cool, dry place away from insects or rodents. Cull any fruit that might have split or become punctured during harvesting. Store in one layer in the smaller black crates.

**Turnips-** Spray off roots. Place in first sink, move to second and third sink when appropriate. Put in cooler at 40°F.

**Watermelon-** Spray melons, getting rid of any excess dirt by rubbing or brushing. Place in cooler or bring to stand for sale.

**Winter Squash-** When cured, rub or wipe of excess dirt before sale. Store in a cool, dry place.

**Appendix I**

**Processing Area Cleaning Record**  
*Before leaving the PA, record all cleaning on this record.*

<i>Date</i>	<i>Sinks</i>	<i>Tables</i>	<i>Floor</i>	<i>Totes</i>	<i>Drains</i>	<i>Tools</i>
-------------	--------------	---------------	--------------	--------------	---------------	--------------