

January 32, 2012

➤ It *is* a leap year right?

➤ Coming soon online:

➤ EChem problem set solutions

➤ Exam #1 Info Page

1

How does current vary with changing E_{applied} ?

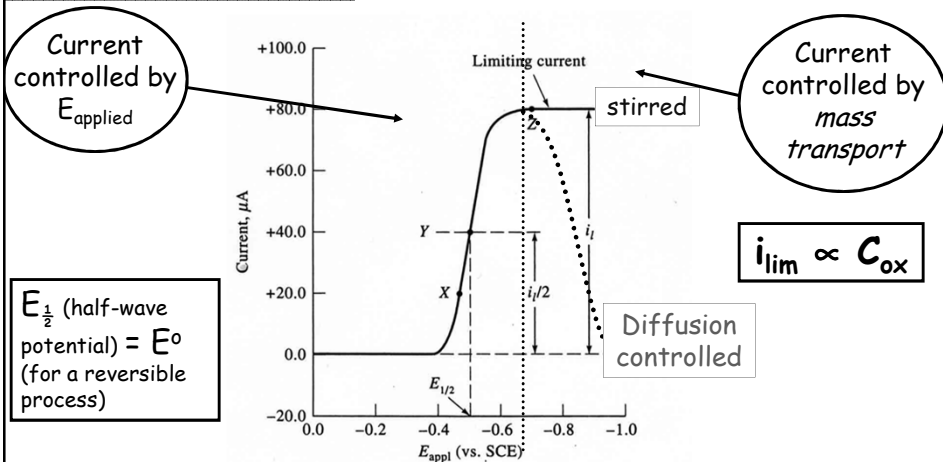

2

Problems

■ Temporal dependence of current (Cottrell Equation)

- current *decreases* with time at fixed E_{applied}

■ Build-up of reduced species on electrode

- Decreases electrode surface area
- Results in a decrease in current as reaction rate decreases

One Solution: *Voltammetry with a DME (dropping Hg electrode)*

- Polarography (*Heyrovsky, 1920's; 1959 Nobel Prize*)

3

Polarography

• DME provides:

- *Fresh electrode surface* with each drop
- *Increasing surface area* as drop expands

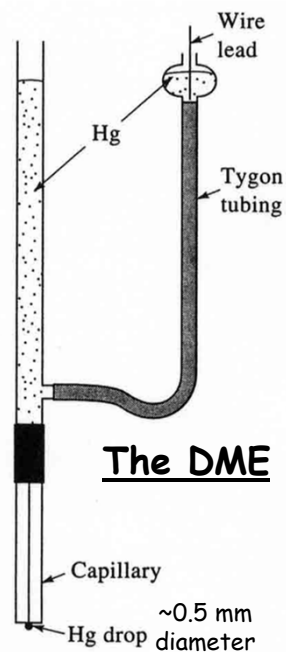

The Ilkovic Equation

- If we take the Cottrell Equation and assume:
- Spherical Hg drop
 - Diffusion-controlled mass transport

$$(i_d)_{\max} = 706 n D_{\text{ox}}^{\frac{1}{2}} m^{2/3} t^{1/6} C_{\text{ox}}$$

Diffusion current, μA Misc constants (607 for $(i_d)_{\text{avg}}$) # e^-/mol Diffusion Coefficient, cm^2/sec Hg mass flow, mg/sec Drop time, sec Bulk solution concentration, mmol/L

5

Current during Drop Lifetime

At a constant E_{applied} :

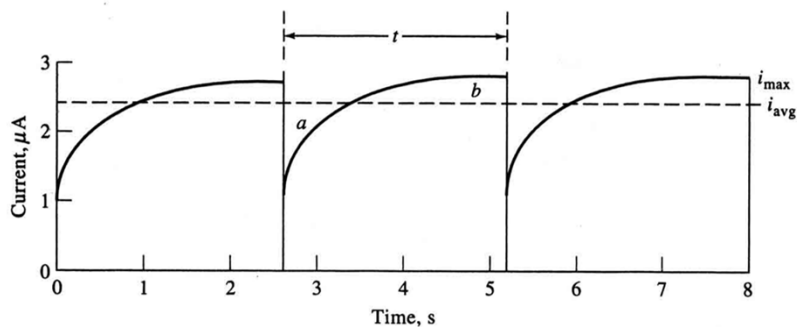

Increasing drop surface area compensates for *decreasing* diffusion-controlled current (Cottrell Equation).

6

Polarogram

For Cd^{2+} :

For a reversible system:

$$E_{\text{appl}} = E^{\circ} - \frac{0.0592}{n} \log\left(\frac{i}{i_d - i}\right)$$

So, at $i = \frac{1}{2} i_d$:

$$E_{\text{appl}} (= E_{\frac{1}{2}}) = E^{\circ}$$

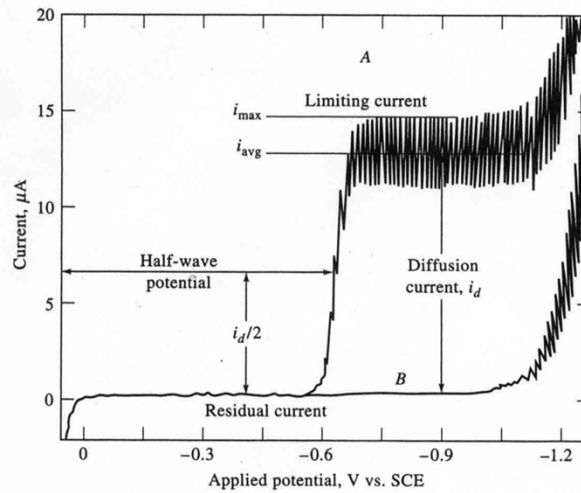

Background Current

Let's look more closely at the electrode/solution interface:

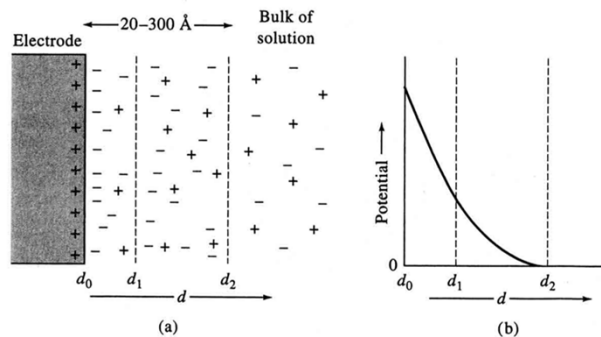

Charge separation \rightarrow capacitance \rightarrow charging current (i_{cc})

Charging Current

Our ability to distinguish i_f from i_{cc} will determine detectability

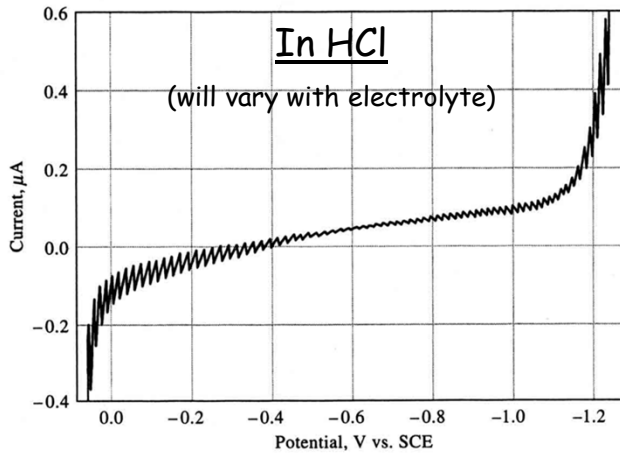

Instrumentation for Polarography

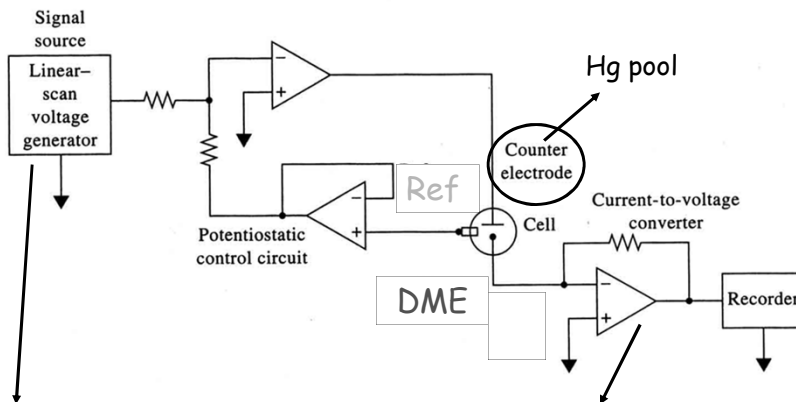

Generates a linear voltage ramp between the DME and Reference electrodes

Measures current flow between DME and Counter electrodes

E_{applied} Ramp Function

• E_{applied} usually limited to:

-2 volts
(solvent/electrolyte reduction)

0 volts
(oxidation of Hg)

• Slope of ramp:

2 - 5 mV/sec

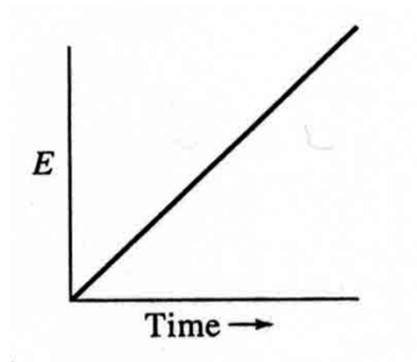

dc Polarography