

# OWNERS MANUAL

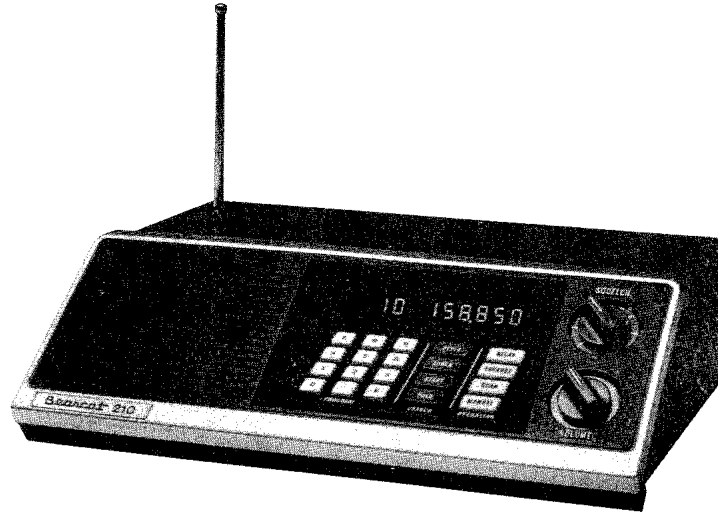

## **Bearcat<sup>®</sup> 210**

### **FIVE BAND FM SCANNING RECEIVER**

Low Band	32-50 MHz	UHF Band	450-470 MHz
Ham	146-148 MHz	UHF (T) Band	470-512 MHz
High Band	148-174 MHz	Plus: UHF Gov't	420-450 MHz

**RECEIVES POLICE. FIRE. WEATHER.  
BUSINESS AND MANY MORE**

MADE IN CUMBERLAND, IND. U.S.A. UNDER ONE OR MORE OF THE FOLLOWING PATENTS:  
3,961,261 3,962,644 4,027,251 and patents pending

MFG. BY —  **Electra COMPANY**

**DIVISION OF MASCO CORPORATION OF INDIANA  
CUMBERLAND, INDIANA 46229**

© Copyright 1978 by Electra Company

## INDEX

Radio Services . . . . .	1	Telephone Tone Squelch . . . . .	6
Safety Caution . . . . .	1	Safety Caution . . . . .	7
General Description . . . . .	2	Mobile Installation . . . . .	7
Specifications . . . . .	2	External Antenna . . . . .	8
Front Panel Features . . . . .	2	Battery Replacement . . . . .	8
Operating Controls . . . . .	3	Birdies . . . . .	9
Operating Instructions . . . . .	3	User Hints . . . . .	9
Programming . . . . .	4	Service . . . . .	10
Lockout . . . . .	4	General Information . . . . .	11
Scan Delay . . . . .	5	Notes . . . . .	13
Search . . . . .	5	Local Services . . . . .	13
Helpful Hints . . . . .	6	Warranty . . . . .	15

### RADIO SERVICES

Amateur (Ham)	Special Emergency	Police
Local Government	Hospitals	Fire
Highway Maintenance	Ambulances	Press
Forestry-Conservation	Physicians	Business
Motion Pictures	Disaster Relief	Railroad
Special Industrial	School Buses	Taxicab
Telephone Maintenance	Power	Marine
Automobile Emergency	Petroleum	Manufacturers
Public Mobile Radio	Forest Products	Motor Carrier
Mobile Telephones	Rural Radio	



**UNDERWRITERS  
LABORATORIES  
LISTED**

Certified in accordance with FCC  
Rules and Regulations Part 15.63  
as of date of manufacture.

**CAUTION**  
TO PREVENT FIRE OR SHOCK  
HAZARD, DO NOT EXPOSE THIS  
APPLIANCE TO RAIN  
OR MOISTURE.

For future reference write in the model number and serial number here. You will find them on the back of the unit.

Model No. \_\_\_\_\_ Serial No. \_\_\_\_\_

Purchased from: \_\_\_\_\_ Date \_\_\_\_\_

## GENERAL DESCRIPTION

Bearcat 210 is a 10 channel, five-band FM scanning police/public service radio receiver. Its micro-computer control makes scanning easy and fun. The search feature allows previously unknown signals to be located and monitored. Bearcat 210 provides keyboard control and programming, digital display of channel and frequency, scan delay selectable by channel, individual channel lockout, 117Vac or 12Vdc operation, all solid state circuitry including five custom integrated circuits designed especially for Bearcat 210, external antenna jack, external speaker jack, track tuning system for full band coverage and frequency synthesis which eliminates the need for channel crystals.

## SPECIFICATIONS\*

<b>Size:</b>	7 x 3½ x 9
<b>Weight:</b>	4½ lbs
<b>Cabinet:</b>	Vinyl-clad steel
<b>Power Requirements:</b>	117Vac 50-60 Hz 11W; or 13.8Vdc 6W
<b>Antenna:</b>	Telescoping antenna electronically tuned for all bands (supplied). Connector provided for outside antenna.
<b>Input Impedance:</b>	50-70 ohms
<b>Sensitivity:</b>	H and L bands ±5KHz deviation — .6uv/12db SINAD. U and T bands slightly less.
<b>Channels:</b>	10 with synthesized circuitry — no crystals required.
<b>Frequency Ranges:</b>	Low Band 32-50 MHz Ham Band 146-148MHz High Band 148-174MHz UHF Band 450-470MHz UHF "T" Band 470-512MHz Plus: Gov't UHF 420-450MHz
<b>Scan Rate:</b>	Approximately 20 channels per second.

## FRONT PANEL FEATURES:

On/Off - Volume Control  
Squelch Control  
Display  
Keyboard  
Speaker

\* Specifications are typical and subject to change without notice.

## OPERATING CONTROLS

1. ON/OFF-VOLUME: Turns the receiver ON and OFF and varies the volume.
2. SQUELCH: Keeps the radio quiet unless a signal is being received and allows the radio to scan or search for a signal.
3. DISPLAY PANEL: Indicates channel number and frequency, Delay (□), Lockout (—), Scanning Action (Rolling Zeros), Programming Error (E).
4. KEYBOARD:

Numeric Keys  thru  and decimal point  used to program frequencies into the scanner.

enters frequency.

enters upper SEARCH limit.

enters lower SEARCH limit.

starts or restarts SEARCH.

stops the SEARCH.

delays displayed channel.

locks out displayed channel.

starts SCAN.

for manual operation and channel stepping.

## OPERATING INSTRUCTIONS

The purpose of this section is to allow you to start listening to your new scanner as soon as possible. Read and carefully follow these instructions.

1. Unpack the unit from the carton (save the carton for possible future use). Check your Bearcat 210 for shipping damage. If damage has occurred, contact your dealer immediately.
2. Attach the power cord into the back of the radio and then into a 117 Vac 60Hz outlet. See later instructions for vehicular installation.
3. Screw antenna (clockwise) into radio.
4. Turn the unit ON by turning the VOLUME control clockwise approximately 1/3 of its rotation.
5. Adjust the "SQUELCH" control clockwise until you hear background noise; then turn it back counter-clockwise until the noise disappears.
6. You are now ready to program frequencies into your receiver.

## PROGRAMMING FREQUENCIES INTO RECEIVER

You can program your receiver to scan ten different frequencies – one for each of the ten channels.

Press the **Manual** key. The channel number will show on the left side of the display panel.

Enter the frequency you wish to receive on that channel by pressing the appropriate program keys including decimal point key. Then, press the **E** (enter) key.

### EXAMPLES

Manually step to desired channel PRESS: <b>Manual</b> For: 35.400MHz PRESS: <b>3 5 . 4 E</b> Read: 35.400
PRESS: <b>Manual</b> (step to next channel) For: 471.1375MHz PRESS: <b>4 7 1 . 1 3 7 5 E</b> Read: 471.137 (3-place round-off)
In case of a mistake on one channel PRESS: <b>E</b> (then program correct number)

If you attempt to program a frequency that is outside the tuning range of the receiver, an “E” (error) appears on the display. If this happens, simply enter a new frequency.

**NOTE:** Be certain to make a record of the frequencies you have programmed in case of accidental erasure. Always turn the receiver OFF with the front panel Vol/ON/OFF control before plugging or unplugging the power cord. Failure to follow this procedure may result in loss of one or two programmed frequencies.

## LOCKOUT

You may wish to program a continuous broadcast frequency (such as NOAA weather) into the receiver but lock it out of automatic scanning.

To lockout PRESS: <b>Manual</b> (step to that channel) PRESS: <b>Lockout</b> (minus sign appears by frequency)
To “restore” PRESS: <b>Lockout</b> again. (minus sign disappears).

## SCAN DELAY

The BC 210 may be programmed to pause for about two seconds after a transmission on any selected channel. This is useful when both sides of a conversation are transmitted on the same frequency.

For scan delay PRESS:  (step to that channel)  
PRESS:  (  symbol appears at channel number).  
To remove delay PRESS:  again. (symbol disappears).

**NOTE:** If radio is turned OFF, programmed LOCKOUT and DELAY are automatically removed.

## SEARCH

SEARCH is used for finding activity on unknown frequencies. Manually step to the channel you want to use. Record that frequency as it will be erased when SEARCH begins. Follow example.

To search from 146.500MHz to 146.950MHz  
PRESS:  (step to channel you want to use)  
PRESS:

When searching stops on a frequency

To move on PRESS:

To stay on that signal PRESS:

To store that frequency in that channel

PRESS:  (you are now on next channel)

For same search range on this channel

PRESS:

To search between new limits, repeat above.

If an "E" appears in place of a frequency

1. An out-of-band frequency was attempted, or
2. Search limits were not in the same band.

## **SEARCH (Con't.)**

The SEARCH feature opens up a whole new world of discovery. The following user hints are offered to help you gain the maximum enjoyment from your new radio.

First, search a small segment of frequencies at a time. This will increase the speed of finding a new frequency which might be on the air intermittently.

The SEARCH mode may be used to "scan" a large number of channels. For example the 45 channel Marine Band (156.275-157.425 MHz) may be scanned by setting the proper limits and using the SEARCH mode. This same method may also be used to search 2 meter Ham Band (146.000-148.000MHz) or a portion of the telephone channels (152.480-152.840 MHz).

Because of the complex way in which the Bearcat 210 operates, some internal signals are generated which may interfere with reception of some frequencies. These interferences are called "birdies." They exist in most radios but are noticed more in the BC-210 because it finds them like it finds other signals, wherever they may be. If one of these birdies is encountered in SEARCH, the SEARCH will halt each time that frequency is encountered. You must press the Start button to continue searching. Sometimes it is possible to set the search limits to avoid these frequencies. A list of some of them will be found on page 9 of this manual.

Occasionally a signal may be received at more than one indicated frequency, or a signal may be received which is not even in the tuning range of the radio. Like the birdies, these "spurious responses," often from TV or FM stations, are due to signal harmonics and the complex nature of the radio. Again, interference from these signals during SEARCH will be minimized if small segments are searched.

## **TELEPHONE TONE SQUELCH**

Ordinary scanners will stop on mobile telephone channels when the marker tone is present. This 2 KHz tone marks the next channel in a service group which will become active. Bearcat 210 has special circuitry to keep it from remaining on this channel until it becomes active. A short beep will be heard as the Bearcat 210 scans or searches past a marked channel. Other tones are used to indicate off-hook, ringing and other conditions. These tones are not bypassed because they indicate active channels.

## **SAFETY CAUTION**

This is an electrical appliance and as such can be dangerous, if used improperly. It has been listed by the Underwriters' Laboratories which sets standards for safety; however, common sense and reasonable safety precautions must be exercised.

Do not operate this unit while wet, standing in water or otherwise unusually well grounded.

Always plug the AC cord into the radio first and then the AC outlet. Never force a connector to fit improperly.

If you suspect a problem exists, return the unit to Electra Company immediately for inspection.

## **MOBILE INSTALLATION**

This receiver may be installed in any car, truck, boat, etc., having a 12 VOLT NEGATIVE GROUND SYSTEM.

1. Using the mobile mounting bracket select a location under the dash to hold the Bearcat in the desired position.
2. Mark and drill three mounting holes using a 7/64 drill bit. Secure the bracket with the three no. 6 self-tapping screws included.
3. Insert the two plastic "T" washers in the bracket, flanges turned inward, in the desired pair of mounting holes and secure the receiver in place with the two ¼-20 bolts and two ¼" ID x 9/16" OD flat washers.
4. Attach the enclosed DC power cable and, as indicated on rear of the Bearcat, connect it to the "accessory" or "radio" terminal on the fuse block of the vehicle. The ground screw adjacent to the +13.8 Vdc terminal may be used if a good ground is not provided by the mounting bracket. Using the enclosed connector attach one end to the ground screw and the other to a metal part of the vehicle frame.
5. An external mobile antenna should be used. The installation of a mobile antenna is similar to that described for the outside antenna but requires mobile antenna mounting hardware. Also, the automotive antenna may be used. It should be extended for L or H bands and reduced to approximately 18" for U bands.

The BC 210 is designed for excellent noise immunity, however, the noise generated by some auto electrical systems and other parts of the car is often a problem, particularly in areas of low signal strength. An automotive noise suppression kit, available from most electronic stores, may be helpful.

In some areas it is illegal for unauthorized persons to receive police communications on a mobile receiver. The user of this radio is responsible for obtaining any necessary authorization through local agencies. Electra Company cannot be responsible for any illegal installation or usage.



## EXTERNAL ANTENNA

If an outside antenna is necessary for fringe reception, you may use an “all-band” or “Tri-band” design for Low, High and UHF reception. Acceptable results may also often be obtained on a 40MHz or 155MHz antenna. Such antennas, available at most radio dealers, should be coupled to the receiver external antenna jack by 50 ohm coaxial cable, such as RG-58 A/U, using the supplied automotive type connector.

## BATTERY REPLACEMENT

Bearcat 210 uses a small battery to power its memory circuit so that the channel programming is maintained even when the radio is turned off and power disconnected. This battery must be replaced when it becomes discharged (memory fails) – probably about once per year.

Replace the battery with Mallory 10L123, Ray-O-Vac RW48, or Eveready 393. Any other battery may cause damage to the receiver.

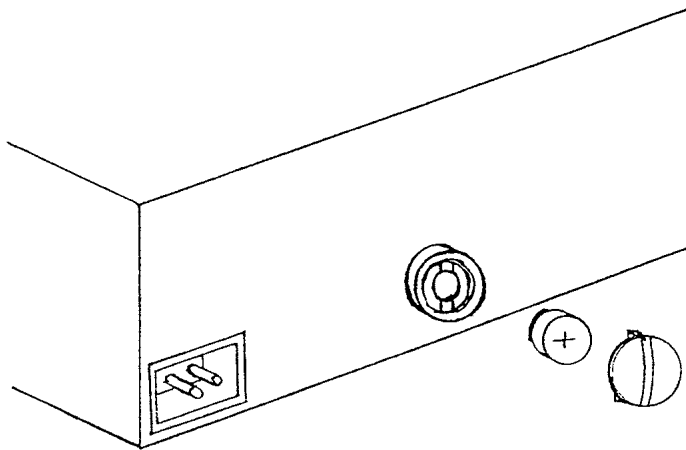

Refer to the figure above. Using a coin, unlatch the cover by turning it slightly counter-clockwise. Remove the battery – a “tool” such as a toothpick may be required to loosen the battery from its mounting. Replace the battery with the negative (button) end inside and the positive (case) end outside. Replace the cover and the radio is now ready to re-program.

## BIRDIES

Following is a list of frequencies which may be difficult or impossible to receive on the Bearcat 210. If programmed with one of these frequencies, the receiver may be noisy on that channel or stop on that channel when no signal is present. The degree to which your radio is affected will vary depending on your location, the antenna you are using, and the other equipment operating nearby.

If the interference is not severe, it may be possible to adjust the squelch control to eliminate the problem without excluding the desired communication.

<u>LOW BAND VHF</u>	<u>HIGH BAND VHF</u>	<u>UHF &amp; T BAND</u>
33.100 MHz	146.400 MHz	451.312 MHz
33.800	146.500	455.625
34.400	147.400	458.325
35.470	148.200	461.025
36.000	148.800	461.700
36.400	149.200	463.700
36.800	150.800	463.725
38.000	153.400	465.150
	153.800	470.900
	154.600	473.600
	161.200	474.500
	161.775	474.950
	163.800	478.100
		479.000
		479.400
		481.700
		482.587
		486.637
		491.575
		496.100

## USER HINTS

Radio equipment usually operates in an environment of man-made electromagnetic noise which radiates from power lines, fluorescent lights, motors, appliances, ignition systems, etc. Modern radios are designed to minimize interference from such sources but operation may be affected under conditions of unusually strong noise.

Distant, weak, "skip" or noise signals may be received by this receiver because of its high sensitivity. Whenever such conditions interrupt scanning or whenever a very busy channel prevents reception of other desired signals, the affected channel may be bypassed by means of the lockout feature.

The BC 210 has high noise immunity because of the quieting squelch system. However, in cases of strong interfering noise or signals, it may be desirable to reduce the length of the antenna to reduce noise pickup below a critical level. This may be very effective in medium and strong signal areas.

Continuous-carrier signals such as the NOAA weather broadcasts on 162.550, 162.475 or 162.400MHz, which are available in many areas, may be received or locked out as desired by use of the individual channel lockout feature.

When moving or shipping the radio, remove the telescoping antenna to avoid damage to it or to the internal circuit assemblies.

## SERVICE

### Determining Need for Service:

If your scanner doesn't seem to be functioning properly:

1. Be sure the radio is plugged into a working AC outlet.
2. Is it turned ON at Volume Control?
3. Rotate squelch full clockwise and turn volume full clockwise. You should hear a loud hissing noise. If not, do not go to Step 4. Verify that another appliance will work on that AC outlet.
4. If (3) occurs, rotate squelch counter-clockwise just until the noise stops. Rotating it too far decreases the radio's ability to hear.
5. Press **[Scan]**. The display should indicate a left-to-right scanning action. (Rolling Zeros). If a signal occurs on a channel it should stop scanning.
6. Press **[Manual]** repetitively, stepping through the 10 channels verifying that the frequencies are proper for your area.
7. Check that the telescoping antenna is properly installed.
8. Place the radio near a window (usually signals are stronger near windows). Be certain there are signals in your area.
9. Leave the radio scanning 20 to 30 minutes. If nothing is heard by that time, then something is probably wrong with the radio and you should contact Electra Company.
10. When moving or shipping the radio, remove the telescoping antenna to avoid damage to it or to the internal circuit assemblies.
11. It is strongly recommended that servicing of this receiver be done by Electra Company. Special equipment and skills are maintained at the factory to give fast and efficient service on all of our products. When returning radio receivers to the factory for service, pack very carefully and include a brief, concise description of the difficulty you are having.

For Service return your Bearcat 210 to:

**ELECTRA COMPANY**  
Division of Masco Corporation of Indiana  
300 South on East County Line Road  
Cumberland, Indiana 46229

## GENERAL INFORMATION

The electromagnetic (Radio) frequency spectrum is considered a natural resource and the use and pollution of this publicly-owned communication medium is regulated by the Federal Communications Commission. Channel allocation to various services and the assignment, licensing and operational regulation of qualified users are all administered by the F.C.C.

As few as a dozen or as many as 600 of these channels may be in use in your community. Usage is mixed and changing. Some channels are shared -- no complete list can be supplied for your area only. You can learn about most of the active frequencies in your area by searching with your BC 210. Conventional scanning monitor receivers can receive only those frequencies for which you have purchased crystals. Your BC 210 can be programmed to receive any of them quicker than plugging in a crystal, and much quicker than selecting crystals from a box of 6,000 expensive crystals.

The following is an approximate listing of some of the services covered by the Bearcat 210. More than 6,000 channels are included. Only the first and last frequency in each group is shown.

### ABBREVIATIONS

Amateur . . . . .	Ham	33.18 - 33.38 . . . . .	Pet.
Police . . . . .	P. D.	33.42 - 33.98 . . . . .	F. D.
State Police . . . . .	St. P. D.	34.00 - 35.00 . . . . .	Govt.
Fire Department . . . . .	F. D.	35.02 - 35.18 . . . . .	Bus.
Special Emergency . . . . .	Sp. Emer.	35.22 - 35.66 . . . . .	Mob. Tel. & Page
Highway Maintenance . . . . .	Hwy.	35.70 - 35.72 . . . . .	Bus.
Forestry-Conservation . . . . .	Fors. Cons.	35.74 - 35.98 . . . . .	Sp. Ind. & Bus.
Government . . . . .	Govt.	36.00 - 37.00 . . . . .	Govt.
Local Government . . . . .	L. Govt.	37.02 - 37.44 . . . . .	P. D. & L. Govt.
Business Radio . . . . .	Bus.	37.46 - 37.86 . . . . .	Power
Manufacturers . . . . .	Mfg.	37.90 - 37.98 . . . . .	Hwy. & Sp. Emer.
Broadcast Remote . . . . .	BC R.	38.00 - 39.00 . . . . .	Govt.
Mobile Telephone . . . . .	Mob. Tel.	39.02 - 39.98 . . . . .	P. D., L. Govt.
Radio Paging . . . . .	Page	40.00 - 42.00 . . . . .	Govt.
Marine . . . . .	Marine	42.02 - 42.94 . . . . .	St. P. D.
Relay Press . . . . .	Press	42.96 - 43.18 . . . . .	Sp. Ind. & Bus.
Special Industrial . . . . .	Sp. Ind.	43.22 - 43.68 . . . . .	Mob. Tel. Page
Motion Picture . . . . .	Mot. P.	43.70 - 44.60 . . . . .	Trucks, Bus.
Power Utilities . . . . .	Power	44.62 - 45.06 . . . . .	St. P. D., For. Cons.
Petroleum . . . . .	Pet.	45.08 - 45.66 . . . . .	P. D.
Forest Products . . . . .	For. Prod.	45.68 - 46.04 . . . . .	P. D. Hwy., Sp. Emer.
Motor Carrier . . . . .	Buses, Trucks	46.06 - 46.50 . . . . .	F. C.
Taxicab Radio . . . . .	Taxi	46.52 - 46.58 . . . . .	L. Govt.
Railroad . . . . .	R. R.	46.60 - 47.00 . . . . .	Govt.
Automobile Emergency . . . . .	Auto Emer.	47.02 - 47.40 . . . . .	St. Hwy.
Red Cross . . . . .	Red Cross	47.42 - . . . . .	Red Cross
U.S. Weather Bureau . . . . .	U.S.W.B.	47.44 - 47.68 . . . . .	Sp. Ind., Sp. Emer.
U.S. Coastal & Geodetic Survey . . . . .	U.S.C.G.S.	47.70 - 48.54 . . . . .	Power
National Parks . . . . .	Nat. Pk.	48.56 - 49.58 . . . . .	For. Prod., Pet.
Indian Affairs . . . . .	Indian Aff.	49.60 - 50.00 . . . . .	Govt.
Bureau of Reclamation . . . . .	Bur. Recl.		
Department of			
Agriculture & Forestry . . . . .	Agr. & For.		
Land Transportation . . . . .	Land Tr.		

### 30-50MHz Band (.020MHz or 20KHz spacing)

30.01 - 30.56 . . . . .	Govt.
30.56 - 30.62 . . . . .	Sp. Ind.
30.66 - 31.24 . . . . .	Ind. (Pet. For. Cons. Bus., For. Prod.)
31.26 - 31.98 . . . . .	Sp. Ind., For. Cons.
32.00 - 33.00 . . . . .	Govt.
33.02 - 33.16 . . . . .	Hwy., Sp. Emer., Bus.

### 146-148MHz 2 Meter Amateur (Ham) Band

### 148-174MHz Band Mixed Spacing (15, 20, 25KHz)

148.010 - . . . . .	MARS
148.15 - . . . . .	CAP
148.155 - 148.250 . . . . .	MIL
148.290 - 150.750 . . . . .	USN
150.815 - 150.995 . . . . .	Bus.
151.010 - 151.130 . . . . .	Hwy.
151.145 - 151.475 . . . . .	For. Cons.
151.505 - 151.595 . . . . .	Sp. Ind.
151.625 - 151.955 . . . . .	Bus
151.985 - 152.240 . . . . .	Mob. Tel. (RCC)
152.270 - 152.450 . . . . .	Taxi

152.480 - 152.840 . . . . . Mob. Tel. Page  
152.870 - 153.020 . . . . . Sp. Ind., Mot. P.  
153.050 - 153.440 . . . . . Pet., For. Prod.  
153.470 - 153.710 . . . . . Power  
153.740 - 154.115 . . . . . L. Govt.  
154.130 - 154.445 . . . . . F.D.  
154.450 - 154.600 . . . . . Sp. Ind., Pet., Bus.  
154.655 - 155.145 . . . . . P.D., L. Govt., St. P.D.  
155.160 - 155.400 . . . . . Sp. Emer., P.D.  
155.415 - 156.030 . . . . . P.D., L. Govt.  
156.045 - 156.240 . . . . . Hwy., P.D.  
156.275 - 157.425 . . . . . Marine  
157.456 - 157.600 . . . . . Auto Emer.  
157.530 - 157.710 . . . . . Taxi  
157.740 - 158.100 . . . . . Mob. Tel., Page  
158.130 - 158.460 . . . . . Power, For. Prod., Pet.  
158.490 - 158.700 . . . . . Mob. Tel. (RCC)  
158.730 - 158.970 . . . . . P.D., L. Govt.  
158.985 - 159.210 . . . . . P.D. Hwy.  
159.225 - 159.465 . . . . . For. Cons.  
159.510 - 160.200 . . . . . Trucks  
160.215 - 161.565 . . . . . R.R.  
161.600 - 162.000 . . . . . Marine  
162.026 - 162.175 . . . . . Bur. Recl.  
162.400 . . . . . U.S.W.B.  
162.550 . . . . . U.S.W.B.  
163.125 . . . . . Indian Affairs  
163.175 . . . . . Bur. Recl.  
163.275 . . . . . U.S.W.B.  
163.388 - 163.538 . . . . . MIL  
163.825 - 163.975 . . . . . Govt.  
164.025 - 164.075 . . . . . U.S.C.G.S.  
164.175 - 165.188 . . . . . Bur. Recl., Nat. Pk.,  
Govt., Agr. & For.  
169.300 . . . . . F.A.A.  
169.450 - 169.725 . . . . . Ind., Data  
170.150 . . . . . F.D., BC. R.  
170.200 - 170.220 . . . . . U.S.C.G.S.  
170.225 - 170.325 . . . . . Ind., Land Tr.  
170.425 - 170.575 . . . . . For. Cons.  
170.975 - 171.250 . . . . . Govt. Ind., Land Tr.  
171.388 - 172.725 . . . . . Bur. Recl., For. Cons.,  
Ind., Dept. Ag. & For., Govt.  
172.775 . . . . . Nat. Pk.  
173.025 . . . . . U.S.W.B.  
173.075 . . . . . U.S.C.G.S.  
173.204 - Press Relay, Mot. P., Pet. Bur. Recl.

**450-512MHz Band  
(25KHz Spacing)**

450.050 - 450.950 . . . . . Remote Br.  
451.000 - 451.150 . . . . . Util.  
451.175 - 451.750 . . . . . For. Prod., Pet., Pwr.,  
Tel. Maint.  
451.775 - 451.975 . . . . . Spec. Ind.  
452.000 - 452.500 . . . . . Taxi, Mot. Carrier, R.R.  
452.525 - 452.600 . . . . . Auto Club  
452.625 - 452.975 . . . . . Motor Carr., R.R.  
453.000 - 453.975 . . . . . L. Govt., P.D., F.D.  
454.000 - 454.975 . . . . . Mob. Tel.  
455.000 - 455.975 . . . . . Remote Br.  
456.000 - 458.975 . . . . . P.D., F.D., Ind., Lan. Tr.

459.000 - 459.975 . . . . . Domestic Public  
460.000 - 460.625 . . . . . P.D., F.D.  
460.650 - 462.175 . . . . . Bus.  
462.200 - 462.450 . . . . . Taxi  
462.550 - 462.725 . . . . . C.B.  
462.750 - 462.975 . . . . . Bus.  
463.000 - 463.175 . . . . . Med.  
463.200 - 464.975 . . . . . Bus.  
465.000 - 467.500 . . . . . P.D., F.D., Ind., Land Tr.  
467.750 - 467.925 . . . . . Bus.  
467.5375 - 467.7375 . . . . . C.B.  
467.7375 - 469.975 Pub. Safety, Ind., Land Tr.

In some large metropolitan areas, 1 or 2 channels of the "TV Band" (470MHz to 512 MHz) are used for communication purposes. Each station (channels 14 through 20) utilizes 6MHz:

- 470-476 T.V. Channel 14
- 476-482 T.V. Channel 15
- 482-488 T.V. Channel 16
- 488-494 T.V. Channel 17
- 494-500 T.V. Channel 18
- 500-506 T.V. Channel 19
- 506-512 T.V. Channel 20

Where these frequencies are assigned for communication purposes, in lieu of a T.V. station, the 6MHz segment is allocated as shown here for channel 14 (470-476MHz).

470.0125 - 470.2875 . . . . . Domestic Public,  
(Base, Mob.)  
470.3125 - 471.1375 . . . . . Public Safety  
471.1625 - 471.2875 . . . . . Reserve Pool A  
471.3125 - 471.4125 . . . . . Pwr., Tel. Maint.  
471.4375 - 471.6375 . . . . . Spec. Ind.  
471.6625 - 471.7875 . . . . . Reserve Pool B  
471.8125 - 472.3375 . . . . . Bus.  
472.3625 - 472.4375 . . . . . Taxi  
472.4675 - 472.7875 . . . . . R.R., Motor Carrier,  
Auto Emer.  
472.8125 - 472.9875 . . . . . Pet., For. Prod., Mfg.  
473.0125 - 473.2875 . . . . . Domestic Public  
473.3125 - 474.1375 . . . . . Public Safety  
474.1625 - 474.2875 . . . . . Reserve Pool A  
474.3125 - 474.4125 . . . . . Pwr., Tel. Maint.  
474.4375 - 474.6375 . . . . . Spec. Ind. (Mobile)  
474.6625 - 474.7875 . . . . . Reserve Pool B.  
474.8125 - 475.3375 . . . . . Bus.  
475.3625 - 475.4375 . . . . . Taxi  
475.4625 - 475.7875 . . . . . R.R., Motor Carrier,  
Auto Emer.  
475.8125 - 475.9875 . . . . . Pet., For. Prod., Mfg.

The same allocation pattern is repeated for each of the TV channels 14 thru 20. For example, if channel 17 is assigned for communications in your area, "Taxi" would be 490.3625 to 490.4375 and 493.3625 to 493.4375 (corresponding to 472.3625 to 472.4375 and 475.3625 to 475.4375 above). Note that in the example, we added three TV channels (18MHz) to the channel 14 frequencies.

**NOTES**

CH. 1	_____	6	_____
2	_____	7	_____
3	_____	8	_____
4	_____	9	_____
5	_____	10	_____

**LOCAL SERVICES**

<b>Service</b>	<b>Frequency</b>
_____	_____
_____	_____
_____	_____
_____	_____
_____	_____
_____	_____
_____	_____
_____	_____
_____	_____
_____	_____
_____	_____

**LOCAL SERVICES**

Service	Frequency

### **LIMITED WARRANTY**

This Bearcat® receiver is warranted to the original consumer purchaser to be free from defects in material and workmanship for a period of one (1) year from the date of purchase as shown on purchaser's receipt.

Electra will repair or replace, AT ITS OPTION AND FREE OF CHARGE, during the warranty period, any part which proves defective in material or workmanship under normal installation, use, and service, provided the receiver is returned to our factory (address below) or to one of our authorized Service Centers (list enclosed), TRANSPORTATION CHARGES PREPAID. Receivers returned to our factory or authorized Service Center must be accompanied by a copy of the purchase receipt. In the absence of such purchase receipt, the warranty period shall be one (1) year from the date of manufacture as indicated by the serial number on your unit.

Any damage to this receiver as a result of misuse, abuse, neglect, accident, improper installation, destruction or alteration of the serial number, repair or alteration outside our factory or Service Center, or any use violative of instructions furnished by us WILL VOID THE WARRANTY. THIS WARRANTY IS LIMITED TO DEFECTIVE PARTS REPAIR AND/OR REPLACEMENT ONLY AND EXCLUDES ANY INCIDENTAL AND CONSEQUENTIAL DAMAGES CONNECTED THEREWITH.

Some states do not allow the exclusion of limitation of incidental or consequential damages, so the above limitation or exclusion may not apply to you.

This warranty gives you specific legal rights, and you may also have other rights which vary from state to state. In the event of a problem with warranty service or performance, you may be able to go to a small claims court, or a federal district court.

**ELECTRA COMPANY**  
Division of Masco Corporation of Indiana  
300 South on East County Line Road  
Cumberland, Indiana 46229



## USER HINTS

The Bearcat 210 is a very versatile and complex instrument. There are many operating techniques and easy short cuts in addition to those in the instruction manual. We have, therefore, compiled some additional user hints to make the Bearcat 210 more useful. Also, your input as to new things to try and other observations are welcomed. Some comments and hints:

1. Always remember when programming that the "E" (enter) key must be depressed in order to program the frequency desired. See page 4 of the manual.
2. Each time the radio is turned off, both the lockout and scan delay programs are erased from memory. These must be re-programmed if desired the next time the radio is turned on.
3. When using the "search mode" with UHF frequencies (420 to 512MHz), certain limit combinations may cause an error (E) indication in the display. This is avoided by reentering the limits, using a slightly lower, even number (e.g. 460.000) for the lower limit.
4. Never turn the radio off by pulling the AC cord from the wall socket — you may erase some channels from the memory. Always turn the volume/ON-OFF control OFF first — then disconnect the line cord.

In mobile installations, turn OFF the radio switch before the ignition switch or before disconnecting the Bearcat 210.

When memory is lost, a wrong or "out of limit" frequency will be displayed. This is simply corrected by re-programming the desired frequency.

5. When searching, you may encounter frequencies generated by intermodulation or "birdies" (so called because many times the audio sounds like a steady whistle). Since these frequencies are constant (but only encountered when the exact frequency is programmed such as by searching) the scanner may "hang up" on that frequency and not search or scan. Simply pressing the "start" button skips that frequency and search proceeds.

Intermodulation is a local condition and it is nearly impossible to calculate the extent to which it will be found.

6. When searching, a strong signal may cause the scanner to “lock-on” just prior to the actual frequency (e.g. weather may be received on 162.54 rather than the correct frequency, 162.55). Reception is likely to be “fuzzy.” This is easily corrected – a “tap” of the start button will step the scanner to the correct frequency.  
“Noise” signals appear to the receiver as an active signal and searching may stop and not proceed until the squelch is adjusted. That is, turn the squelch control counter-clockwise until searching resumes.
7. The Bearcat 210 is designed to reject the telephone tone signal and continue to scan. This feature was designed specifically for the 2000Hz telephone tone – other tones may be broadcast by this or other “marker” services – and the radio will not reject these.
8. The Bearcat 210 was designed to search the radio bands at 10 steps per second. This is very fast (although programming “scan delay” will hold frequencies found a bit longer). To manually search, turn the squelch knob all the way clockwise – then “press” the start button to step from frequency to frequency.
9. If you wish to program fewer than 10 channels, rather than lock out the unused channels, you can program your favorite frequency on more than one channel. This will help assure that you won’t miss any broadcasts.
10. When programming, be sure to press all keys firmly in the center – this assures registering each number and avoids errors.
11. So that weaker signals are not missed or “jump off” before broadcasts are complete, set the squelch control as close to the “rushing noise” (threshold position) as possible.
12. When programming high or UHF band frequencies, it is not necessary to enter the decimal point – this is done automatically.