

Modulation Basics

Modulation Basics

- Functional description
- Implementation
- System-level implications

Functional Description

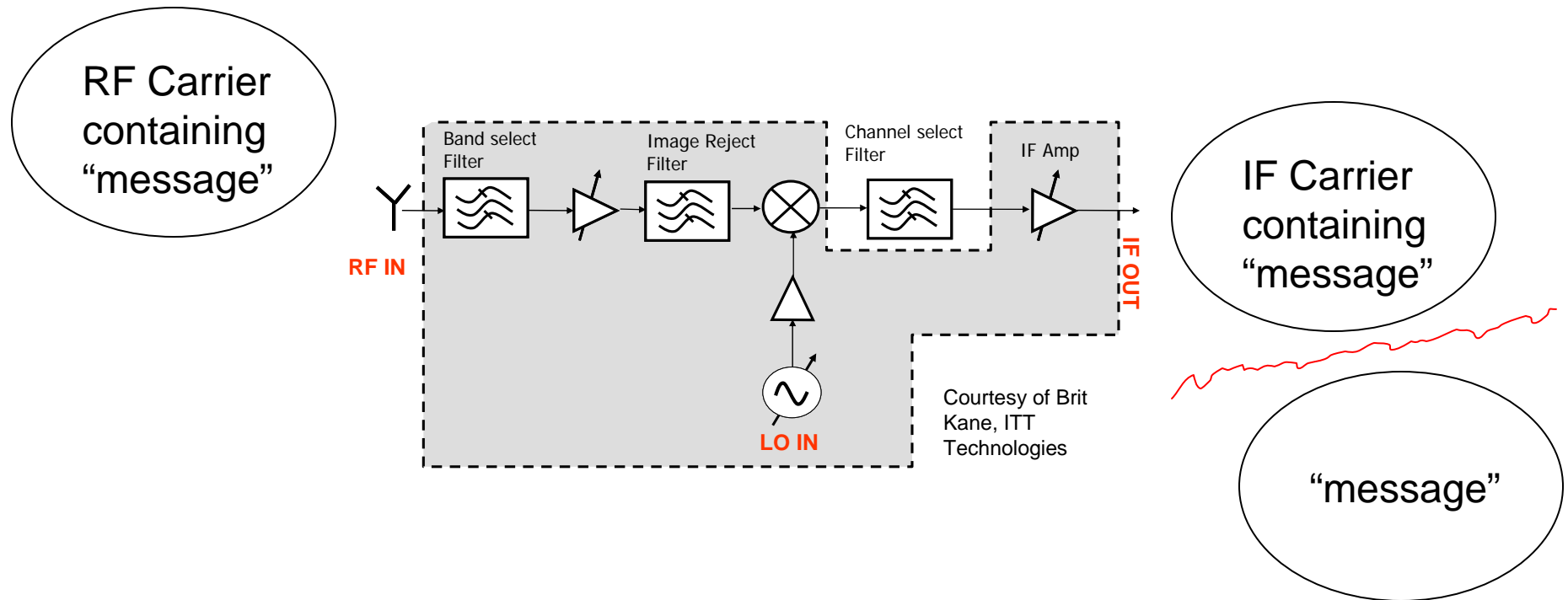

Demodulation in a receiver / Modulation in a transmitter



Interface between the Message Signal and the IF Signal

Implementation – Modulator

- Message Signal:
- IF Carrier Signal:
- Ideal Modulator Output:
- Real Modulator Output:

→ How do we accomplish this?

Implementation – Modulator

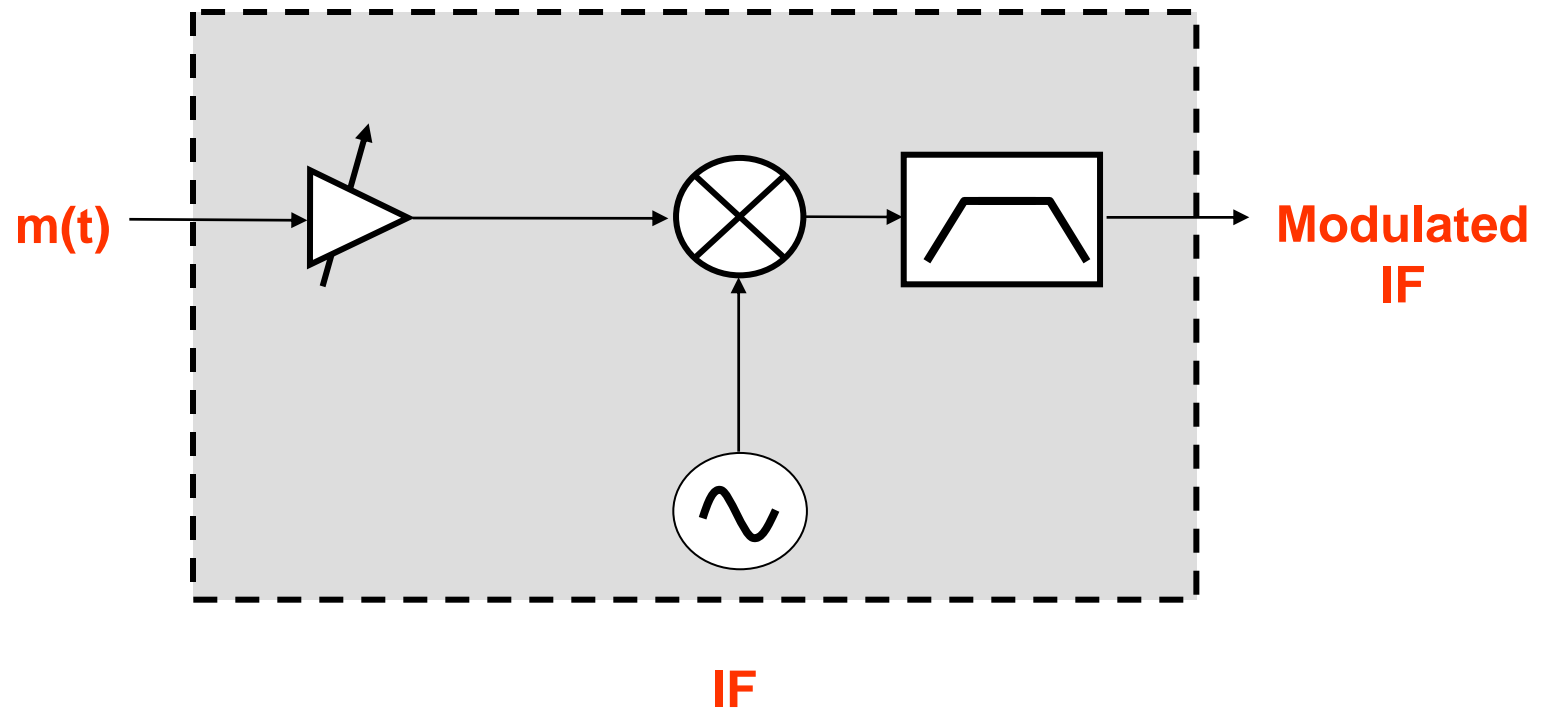

Mod/Demod Synchronization

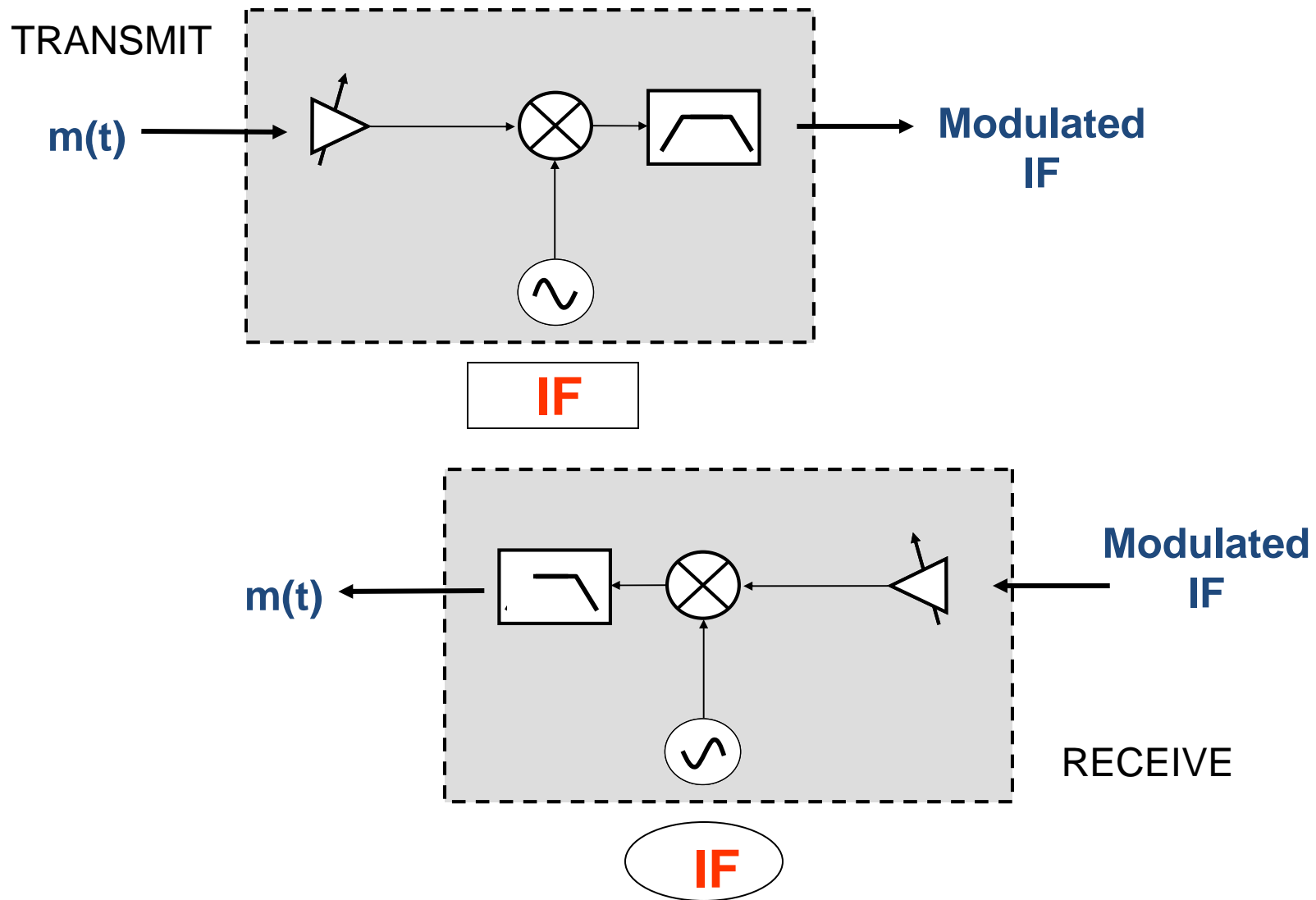

Frequency-Shift Keying

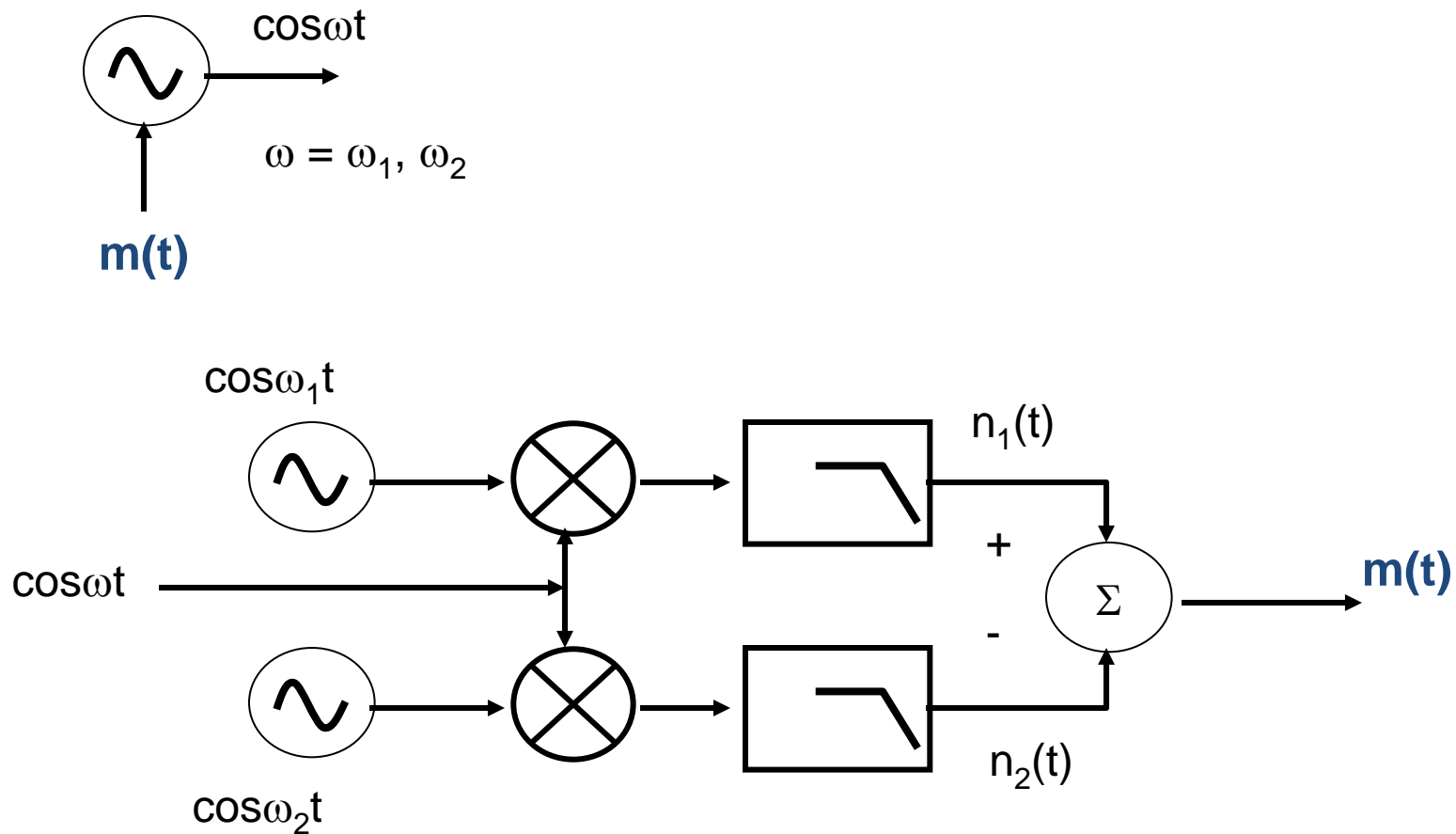

System-Level Implications

- DC power requirement (IF signal)
- Conversion loss → amplifier gain
- Noise → detection limits

Modulation Basics – Conclusions

- Signal processing stage between “message” and IF carrier signal
- Most approaches use mixers but many types of modulation are used (both analog and digital types)
- Filtering important in signal shaping/selection

References

- Microwave and RF Design of Wireless Systems, David M. Pozar, Wiley, 0-471-32282-2