

Short Course
System Dynamics Modeling of Natural Environments: An Introduction to STELLA
Sunday 11 March 2001

Geological Society of America
Northeastern Section
36th Annual Meeting, So. Burlington, VT.

Dr. E. Alan Cassell

Introduction to Building Models with STELLA

On the pages that follow are a number of “generic” STELLA model structures. In my 12 years of modeling natural environments, and in the modeling experiences of others, these generic structures and modifications of them occur frequently. Most of the generic models presented here come from High Performance Systems Inc. and Hannon and Ruth (see attached Bibliography)

Generic STELLA Models

Generic STELLA Models

Stimulus-Response Models

A. Linear Growth Form

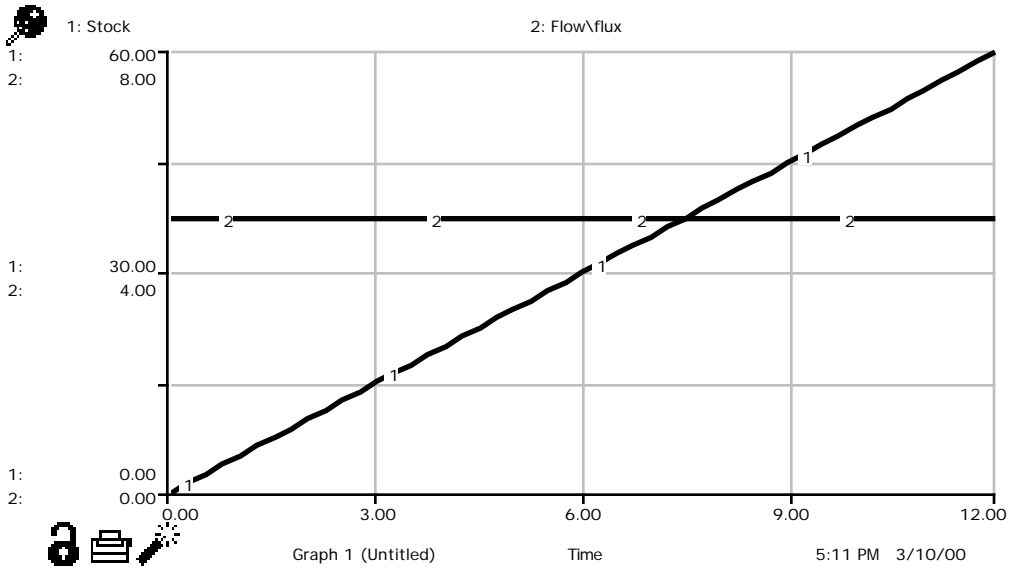
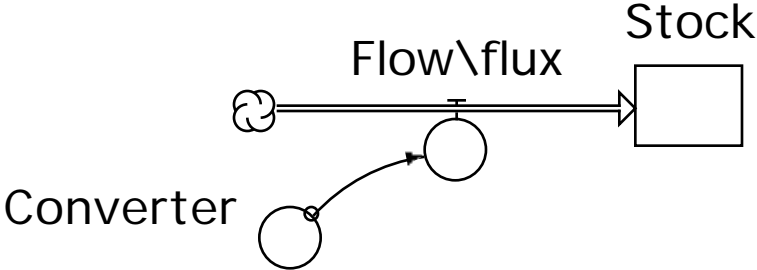

Generic STELLA Models

Stimulus-Response Models

B. Linear Decay Form

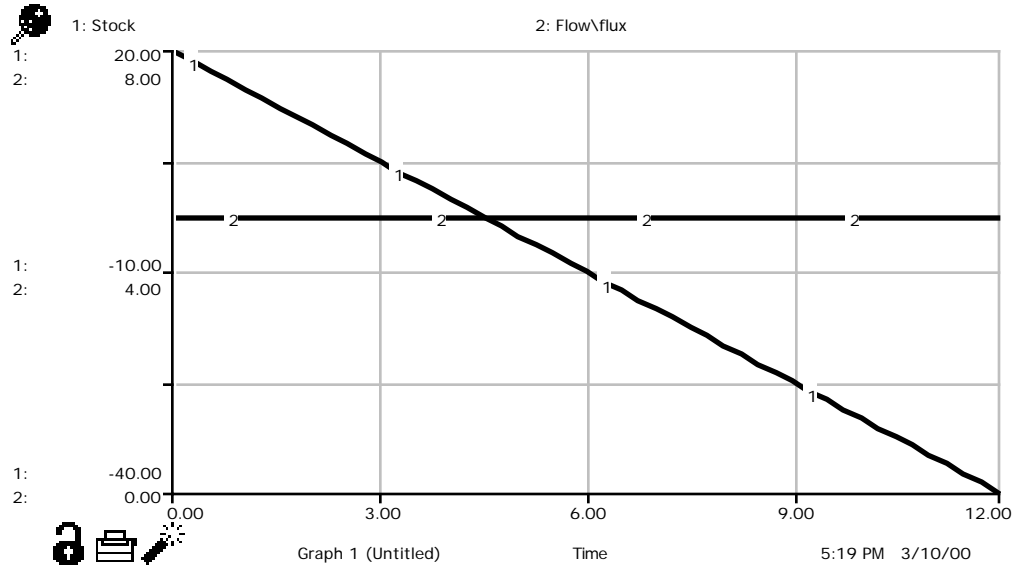
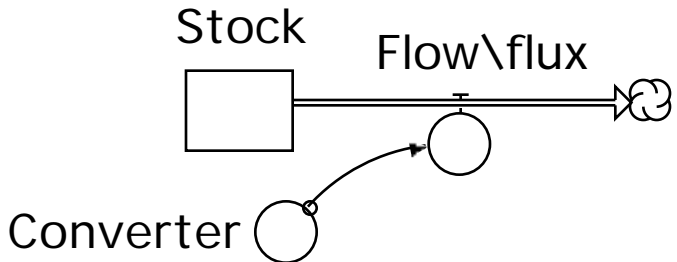

Generic STELLA Models

Stimulus-Response Models

C. Exponential Growth Form (Compounding Process)

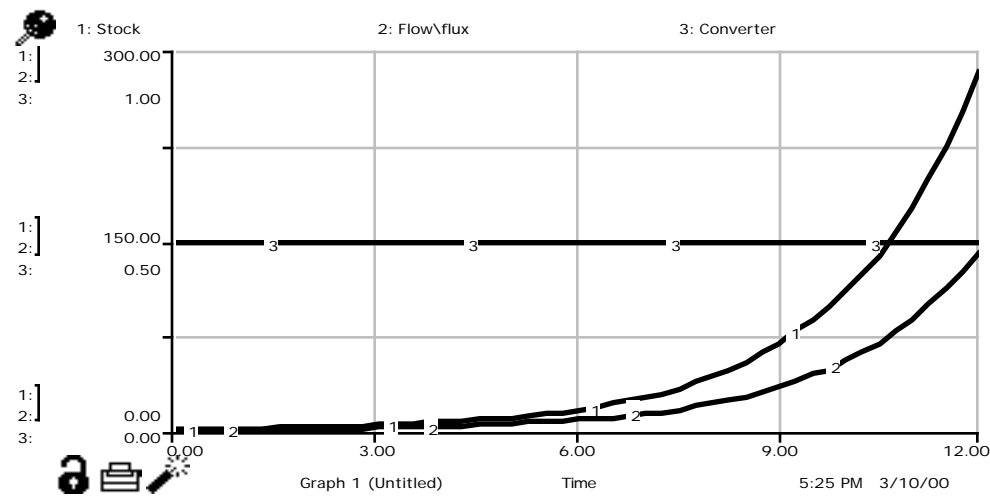
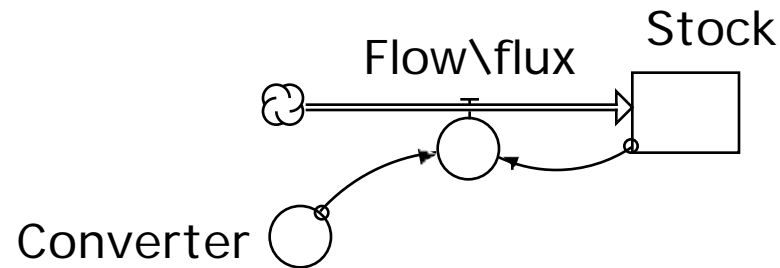

Examples of Use:

**Interest Income, Population Growth, Growth of Sales
Bandwagon Effect, Panic**

Generic STELLA Models

Stimulus-Response Models

D. Exponential Decay Form (Draining Process)

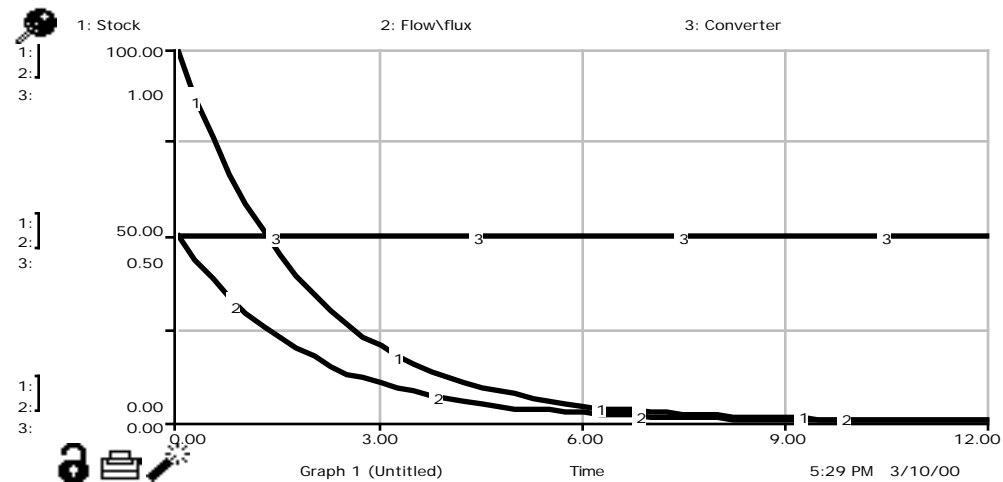
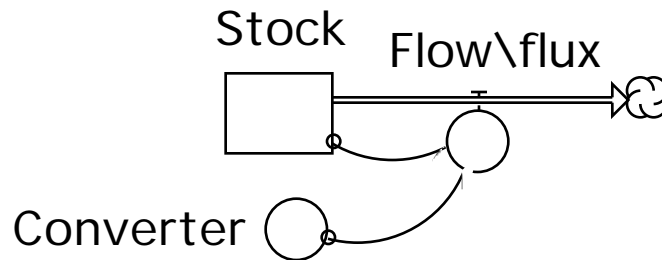

Examples of Use

**Depreciation, Capital Retirement, Forgetting, Stress Dissipation
Decay (radioactive or first-order decay)**

Generic STELLA Models

Convergence Models

A. Goal Seeking Form (Down) (Stock Adjustment Process)

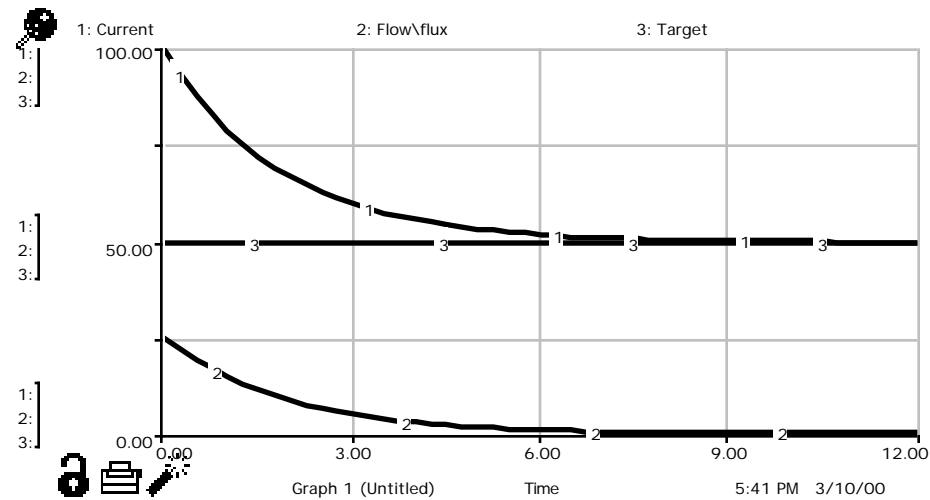
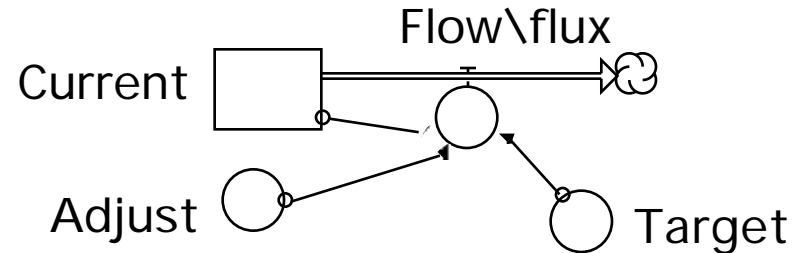

Examples of Use

Erosion of Reputation, Opinion Change, Heat Transfer, Carrying Capacity

Generic STELLA Models

Convergence Models

B. Goal Seeking Form (Up) (Stock Adjustment Process)

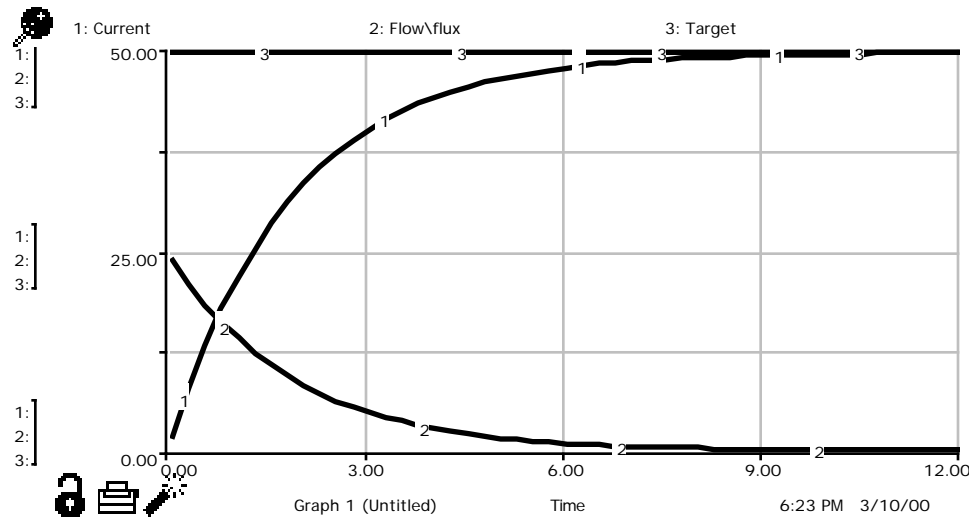
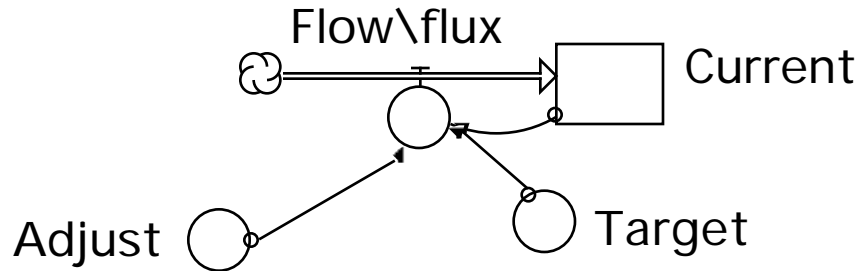

Examples of Use

Increase in Quality, Opinion Change, Heat Transfer, Carrying Capacity

Generic STELLA Models

Convergence Models

C. S-Shaped Growth Form (Logistic Type Process)

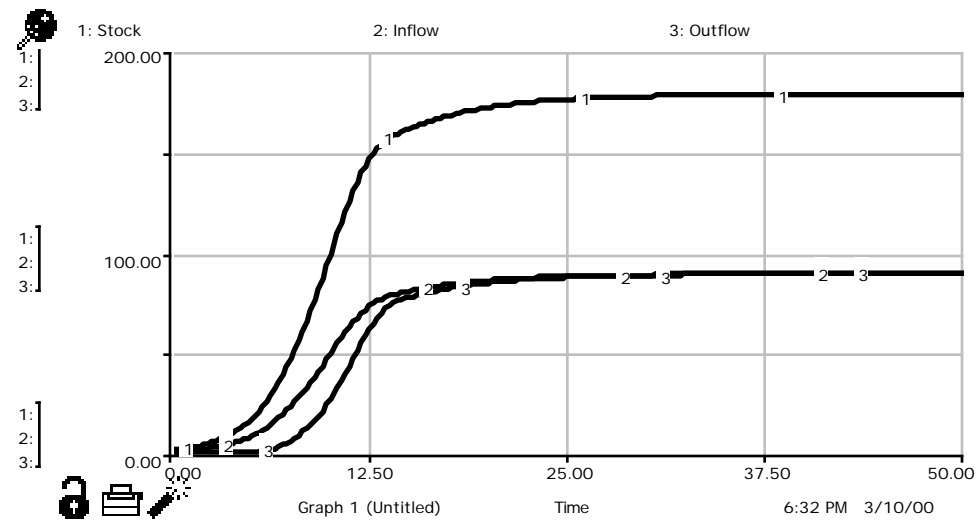
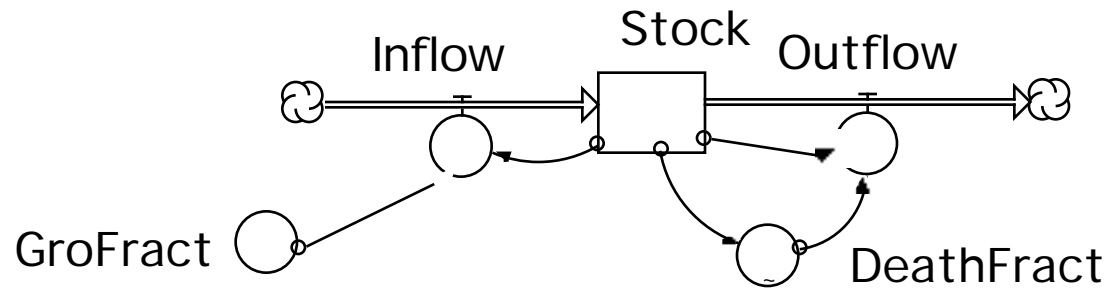

Examples of Use

Competing Rates (+/-), Chemical Equilibria, Logistic Growth

Co-Flow Models

Generic STELLA Models

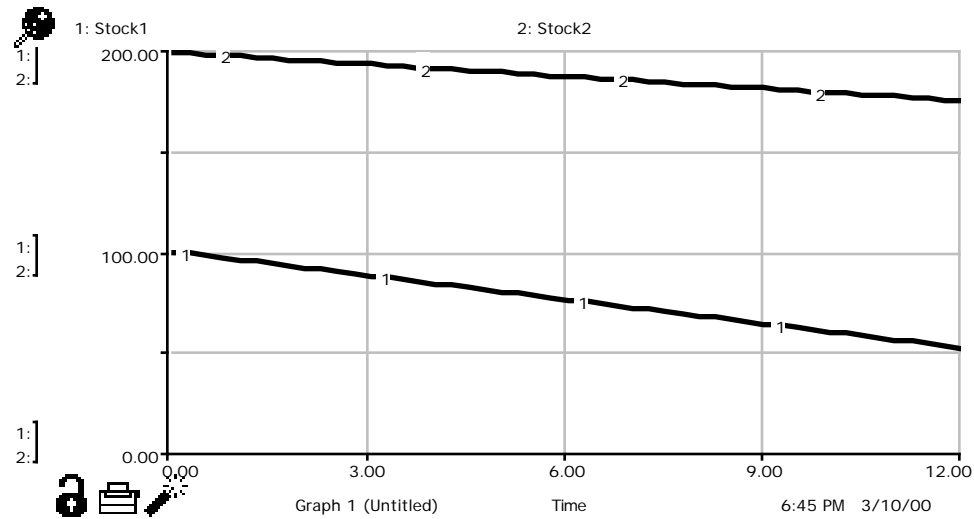
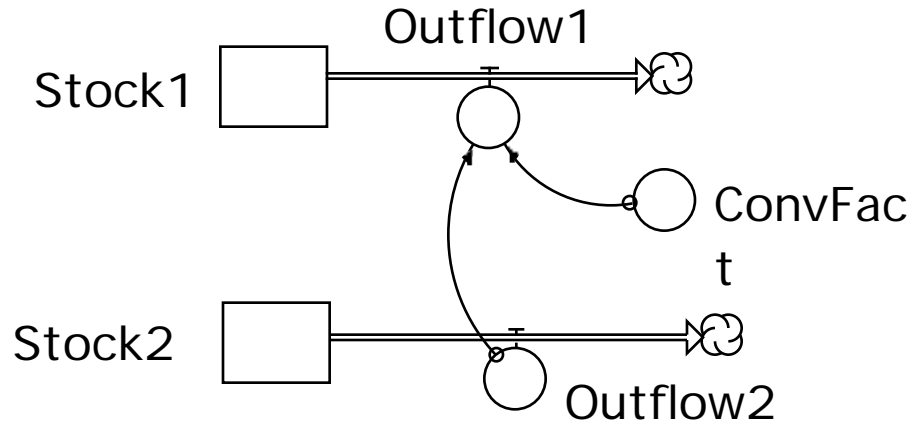

Examples of Use: Relating one stock to another

Generic STELLA Models

External Resource Models

A. General Form

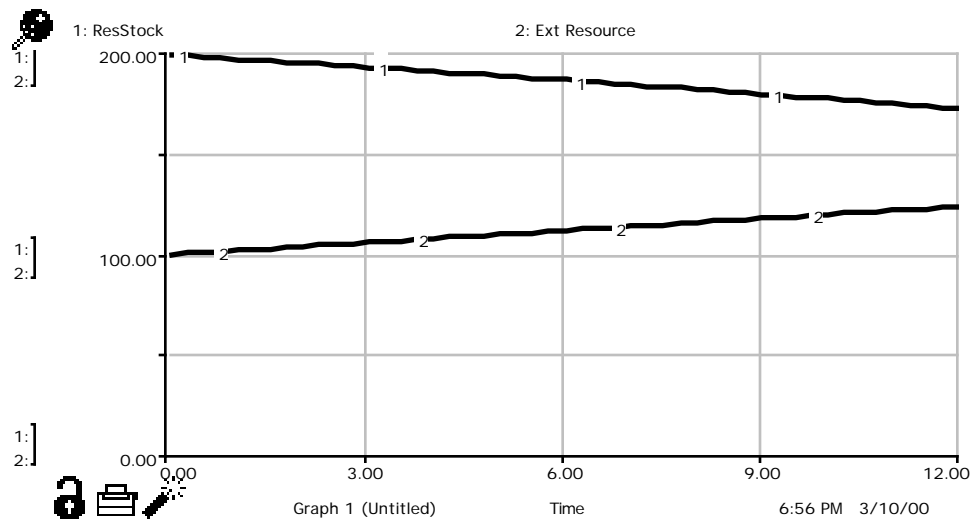
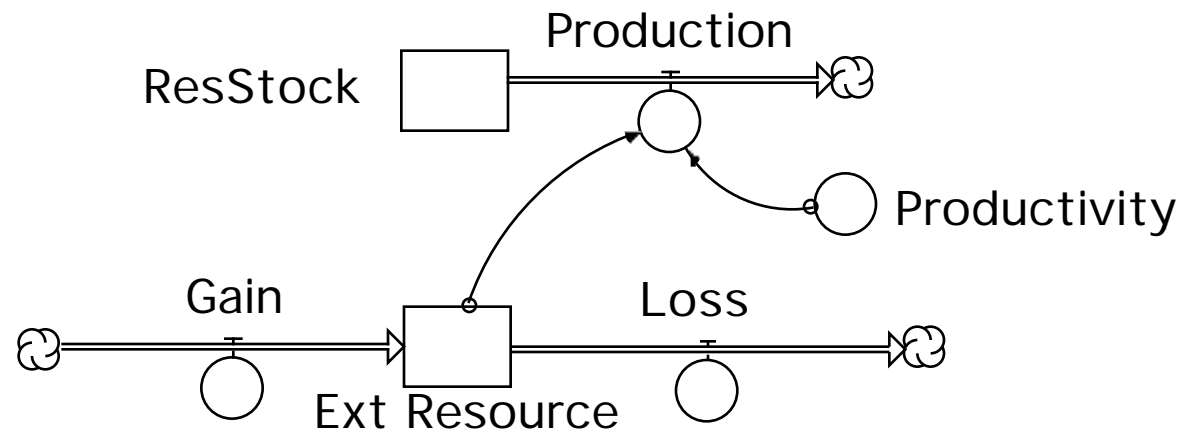

Examples of Use: Production, Lease Income, Sales, Problem Solving

Generic STELLA Models

External Resource Models

B. Overshoot and Collapse

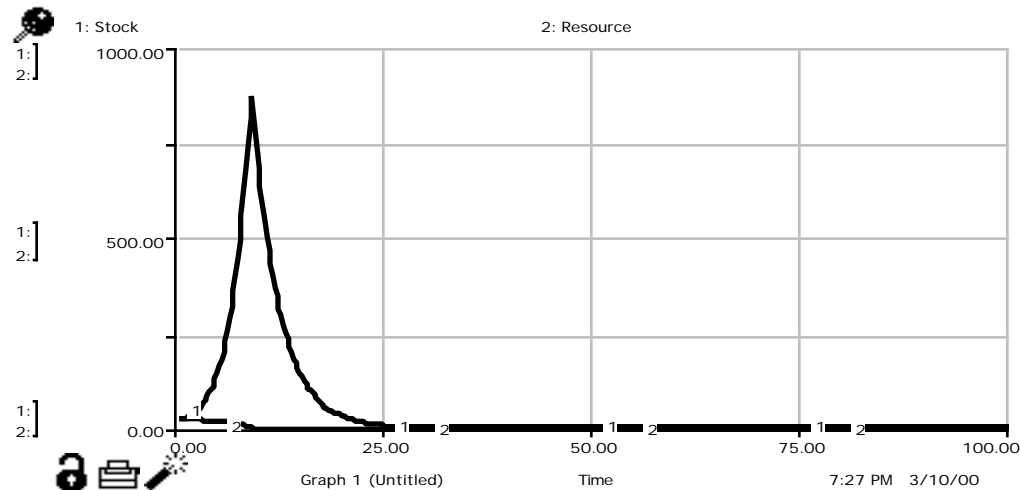
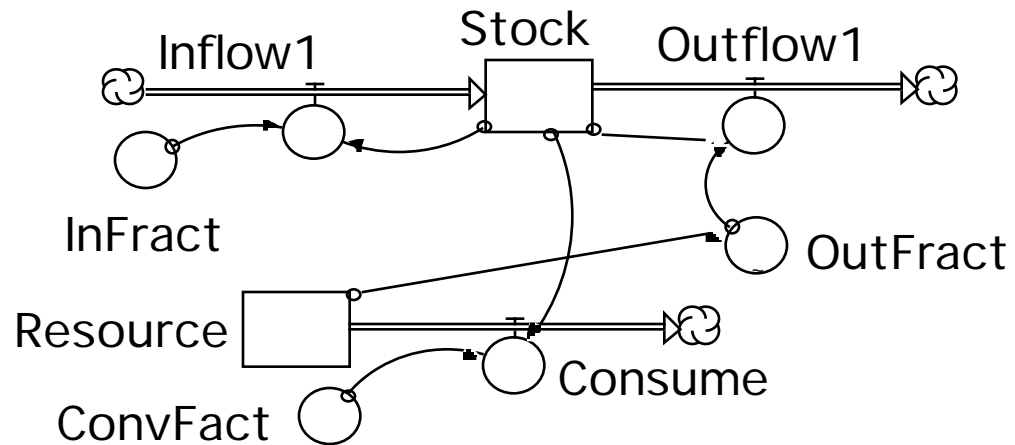

Examples of Use: Population Growth, Resource Depletion

Generic STELLA Models

External Resource Models

C. Oscillation

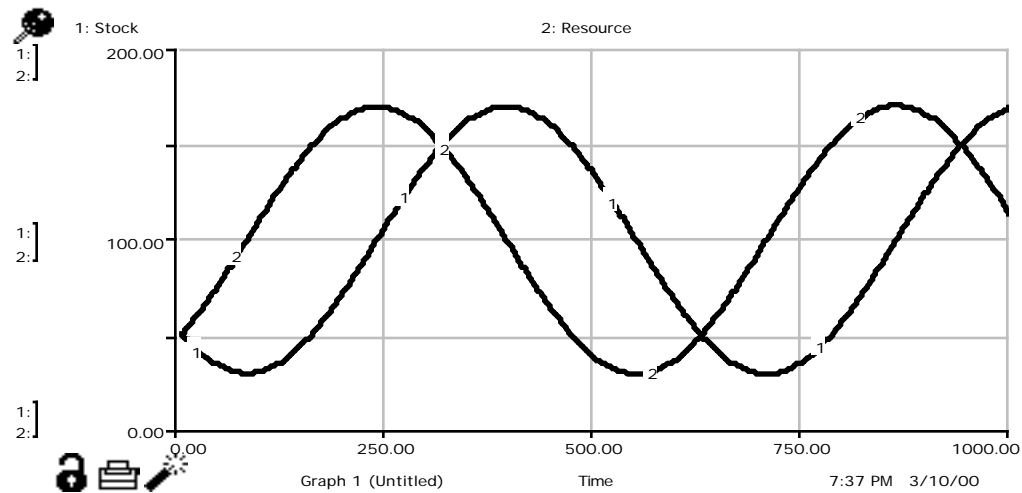
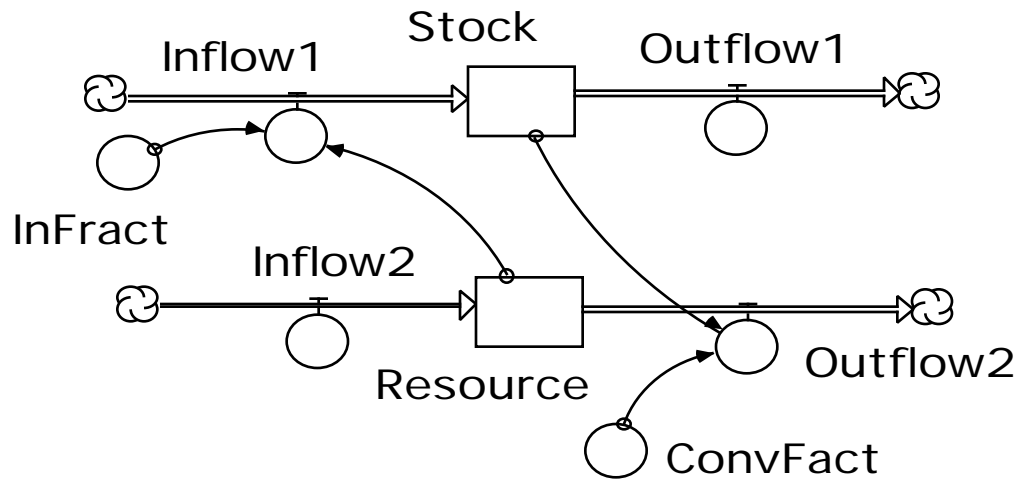

Examples of Use: Population modeling