

Construction Tips

Hoop house construction can be as exacting or casual as you like. However, not paying attention to initial details can cost extra time in the long run, and the resulting structure may not look as nice or stand as long.

Two people with good construction skills can erect a 30' x 96' high tunnel in about a week. The 75 to 100 hour estimated completion time assumes that all materials are on site. Setting up the metal frame, installing baseboards and hipboards, roll-up sides, and building endwalls are included. Additional time will be required for site preparation, utility installation and covering the tunnel with polyethylene film.

Most manufacturers provide instruction manuals with the frame and technical support if needed. Some, however, are less helpful than others in their support so inquire before selecting a company. The most important step is to make certain that the site is square and uniformly pitched or level. If this is done carefully, the frame should install easily.

Instead of step-by-step instructions for constructing a high tunnel, here we offer tips to save you time and money. We hope these recommendations enable you to complete your project with less stress and more confidence.

Start with an adequate selection of tools to make the construction process a pleasant one. Tools to assemble include the following:

- level, level string, chalk line, and transit;
- long-handled mallet or sledge hammer for driving ground stakes;
- post-hole digger for endwall posts;

- cordless drill and drill bits (plus spares) for the various size fasteners you plan to use;
- good step ladder;
- socket set;
- drift punch or pipe wrench;
- miter saw or circular saw;
- speed square;
- hacksaw or saws-all;
- power cord; and
- tape measures (12', 25', and 100').

An experienced high tunnel builder advises: “a cordless drill (preferably one with ample batteries) will be your best friend for fastening those millions of quarter inch bolts and nuts.”

Batter Boards

It is important to set up batter boards at the start of high tunnel construction (see *Diagram 4 below*). The small amount of extra time involved will be well-rewarded by the increased ease of construction. The use of these semi-permanent building markers is described at www.dulley.com/deck/deck01.shtml.

Batter boards define the corners and heights of the high tunnel. They allow you to erect the structure with

confidence whenever you are ready. There is nothing worse than grabbing an hour here or there to work on a high tunnel only to find that someone bumped the stake and all your work is now out of line.

Ground Posts

As farmers, we are striving for a loose, well-structured soil in which to grow our plants. But we need a medium with the opposite characteristics to support a building. (If you have concerns about your site and its ability to support a high tunnel, check with a qualified professional.)

A high tunnel's foundation is provided by ground posts, which are steel pipes partially buried in the ground. On rocky ground, in high wind areas, or where significant ground disturbance occurred during site preparation, a little additional support may be warranted. In these specific situations or for extra stability, a couple shovels of cement will effectively keep ground pins in place.

A sledgehammer is commonly used to drive in short ground posts. Most companies provide a protective piece

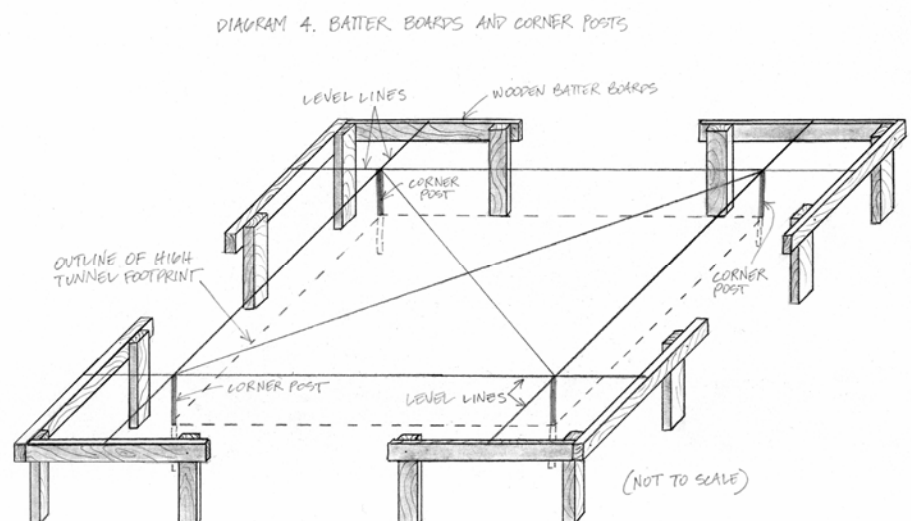

to put in the pipe to protect the end from being damaged or “doughnuting.” For a taller structure with extended ground posts, John Biernbaum (who researches and teaches about high tunnels at Michigan State University) has found that a post or fence pounder works better.

The ground posts at the four corners should be solidly cemented in. For tunnels over 70' long, also cement in the intermediate ground posts in the middle of the long sides. Cement must be placed below the soil freeze zone, as the freezing action can force the ground pin up out of the ground. You may want to use caution when employing cement as this may move the structure into a ‘permanent’ classification.

Steve Moore suggests a good way to keep the ground posts in place so they don't pull out of the cement or slide down: pre-drill the ground posts within 2" or 3" of the bottom and insert a 4" to 6" piece of rebar.

The ground posts need to be in the right location and at the right height. A jig made with two old boards and some broccoli-type rubber bands or thin bungee cords will align the posts with the strings between the batter boards that outline the high tunnel. (See diagram below.) It will also keep the posts at the desired height. This simple device is removed once the cement hardens in 12 to 24 hours.

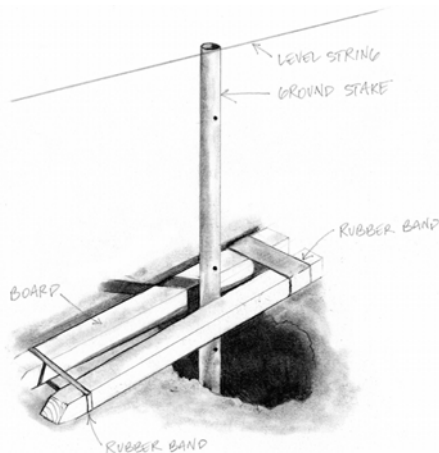

To ensure that the posts are placed at the correct height, use a transit, hose level, or laser level. Then take down the batter boards and run a high-strength nylon mason cord between the corner ground posts. Pull the string as tightly as you can to minimize droop over the long distance. Be careful; if a tight nylon string breaks, it can hurt someone as the end whips past.

The bows – and therefore the ground posts – of most high tunnels are spaced on 4', 5', or 6' centers. A wooden template with notches at 4' (or whatever the bow spacing is) eliminates the need for the time-consuming and awkward task of measuring from bow center to center. Ledgewood and Rimol provide their greenhouse customers with these spacers. They are also easy to make. John Biernbaum regards them as essential for construction.

Alternatively, Steve Moore recommends measuring from the same side of a post every time to attain an accurate center measurement. Taping the end of the measuring tape to the corner ground post is one simple way to do this. A level should be used to ensure the posts are vertical/plumb. A post level that has bubbles at 90 degree angles is useful because both directions can be seen at once.

Bows

Bows typically consist of two or three shorter pieces of metal tubing. Preassemble bows loosely. Do not tighten the bolts. This loose bow assembly will help in purlin installation. (Purlins are horizontal pieces typically made of pipe that is a smaller diameter on one end (swedged) to fit inside the next pipe.)

Historically, pike poles were used to push up large sections of timber framing for barns. Pike poles also have a place in erecting high tunnels.

Raising a heavy bow on a wide tunnel (20' or wider) is best accomplished with at least three people. One person stands at each leg of the bow, and a third pushes the bow up in the air with a pike pole. This is heavy work. Each bow will need to be picked up and wiggled onto the spline/ground posts. Use one or two pike poles to keep the bow assembly from falling while the crew wiggles it onto the ground posts.

Purlins

Purlins help stabilize the high tunnel. They are bolted to the bows, along the length of the structure. Typically a 30' tunnel will have five purlins, including the ridge pole.

The purlins can be attached once the bows are loosely assembled and in place. A platform is much safer than ladders and saves a tremendous amount of time and energy. Use a hay wagon, truck bed, or scaffolding, especially if you can pull it along as you go!

A drift punch or pipe wrench can be used to help align bow and purlin holes. As you attach the purlins, tighten all bow bolts, except those that connect the bow to the ground pin. Finally, when you are at the end bow, with all the purlins in place, you are ready to “plumb” the gable end to straighten the entire bow/purlin assembly.

Attach one string with a plumb bob to the top point of the outside edge of the last bow, and a second ground string to the outside edge of the bottom bow. Allow the plumb bob string to come within 1/8" of the ground string.

A good way to adjust and hold the high tunnel plumb is to attach a come-along to a large immovable object like a tree or truck and then attach a rope or chain from the come-along up to the bow. A come-along's ratcheting mechanism and its steel cable allow for quick and precise alignment of the tunnel. Now you can tighten all

remaining bolts and install the wind braces.

Baseboards

The baseboards sit on the ground along the sides of a high tunnel. They are bolted to the ground posts. Use 1.5" x 8" lumber for baseboards.

Consider sourcing your lumber from local family-owned and operated sawmills. Often boards from these mills are sawn several inches longer than their designated length, rather than being trimmed down to an exact, even foot measure. This extra length will allow you to cut the ends at a 45 degree angle for joining together at the bows with a 1/4" machine bolt (*see diagram below*).

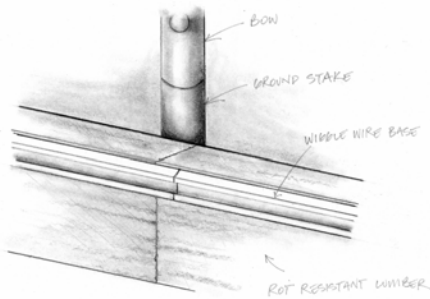

Use a long 1/4" bit to drill out the holes for the bolt through the wood from the inside of the high tunnel. This added length is helpful when attaching framing to bows.

Machine bolts are superior to carriage bolts for attaching the poly hold-down strips to the baseboard. Carriage bolts are often used for this purpose, but they rust fast. When the baseboard needs to be replaced, sometimes the nuts are stuck in place and won't turn. With a wrench on either side of the nut and bolt, the machine bolts will break off much faster and easier than hack sawing carriage bolts, which only turn in the wood.

While bolts may be better for attaching the base boards and hip boards to the bows, galvanized pipe straps can also do a good job, as long as the pipe strap is also tek-screwed to

the bow. Ted Blomgren recommends using a washer on the wood screw.

The frame will be complete after the hip board (2" x 6" lumber) along with "poly lock" or "wobble wire" base is attached to the bows approximately 5' or 6' off the ground. (Poly lock is the trade name for an extrusion for attaching the polyethylene film to the structure. It serves the same purpose as wobble wire.) This will serve as the point of attachment for the plastic covering.

The hip board should be inspected at each change of polyethylene to make sure it will be sound for another four or five years. Farmers should be aware of rot and ready to replace the baseboard as necessary; the plastic need not be removed to do so.

Gable Ends

Doors should be large enough for ventilation and easy access. They can span even the full width of the high tunnel. To maximize airflow and accessibility, some farmers construct removable end walls. A smaller, personal door that opens inward makes a convenient winter passage.

Unless the high tunnel will have very wide doors, some tasks such as adding compost, tilling the soil, and installing utilities are best accomplished before the gable ends are closed in and access is restricted.

Gable end framing can be done with steel or wood. If using wood, either select one of the rot-resistant species recommended for the baseboards (*see materials section*) or be prepared to replace the wood as needed. Steve Moore uses rough sawn 2 x 4s to frame the gable end. When the wood rots right at the soil line where moisture and air meet, rather than take apart the whole assembly, he just pounds in a U-shaped steel fence post and lag or machine bolts it to the post that had rotted off. "This buys me a good many more years service," he says.

If you use a rigid gable-end covering, such as polycarbonate, the outside of the baseboard will need to be flush with the outside of the bow. To make it flush, attach an 8" piece of universal corner (a thin-walled piece of angle iron with multiple holes for bolting) with the same bolts that hold the side baseboard.

Insulation

In cold climates, insulation can make a significant difference in the performance of high tunnels. In Zone 6, burying 1" thick by 2' wide rigid foam (i.e. polystyrene) isolates frozen ground from growing areas. The thickness and depth of insulation should be modified according to your climatic zone. This foam should be buried at an angle to gain more benefit from the thermal mass of the earth. The angled placement also makes installation easier and allows space for the cement support at the bottom of the ground pin (*see diagram below*). Insulation can also be used in pathways and along the lower portion of the sidewalls.

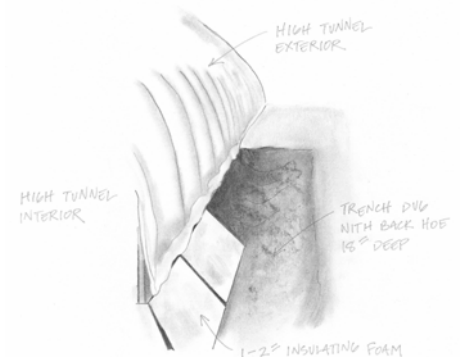

Hiring Out Construction

For some farmers, hiring an experienced crew to do the installation may be the best option. The estimated labor cost for basic high tunnel construction used to be fifty cents to one dollar per square foot. However, due to inflation, the labor bill for high tunnel construction in previous years may not be relevant for estimating costs under current conditions. Like any construction project today, expect skilled contractors to be expensive.

Bending Your Own Frames

Rather than purchasing a hoop house kit, some farmers choose to bend their own. A good role model for this activity is Ed Person of Ledgewood Greenhouse. This New Hampshire farmer went from bending frames for his own use to developing a substantial independent business that sells and delivers high tunnel frames throughout the Northeast.

For savvy shoppers, fabricating a high tunnel steel frame can save money. It also allows farmers to realize a better design idea, satisfy unique needs, or add onto an existing high tunnel.

Ted and Jan Blomgren bent several Gothic arch high tunnel frames for their farm. Three people worked for about the equivalent of one week fabricating the jigs and bending and drilling the component parts for three and a half 30' x 96' high tunnels with trusses.

At the time, they were able to make their own high tunnel frames for a third of the cost of a kit, thanks to a farmer friend's tip about a supplier of economically priced steel. Ted cautions though that purchasing steel from a local chain link fence supplier might actually cost more than buying a kit with pre-bent, pre-drilled steel.

The Blomgrens' bows consisted of two long side pieces with a shorter, smaller diameter piece at the ridge. In all, they used three sizes of steel pipe—1.9", 1.6" and 1.3" diameter for bow, small ridge bow, and purlins, respectively—to fabricate all the high tunnel components including trusses. The only new tools they needed were a chop saw and drill press outfitted for cutting and drilling steel. After four years, there is no rust at the bends and the galvanized coating has not popped off.

They built the two jigs needed for bending the steel for the bows by replicating a bow they had removed from their existing high tunnel. To bend the steel, they placed a jig, made of two-ply 3/4" plywood and lumber, on the level cement floor of their garage, braced against its foundation. For the easier, shallow bend, they were able to use their sedan with a steel cable attached to the trailer hitch. The more acute portion of the bow required the weight and traction of their heavy John Deere tractor. To compensate for the springback in steel, they bent it until it fit a pattern they had outlined on the floor.

Bending the bows for a high tunnel can be a simpler process. For example, Thomas Christenfeld, a neighbor of the Blomgrens, bent the bows for his Quonset-style greenhouse using a silo as a jig. He stuck one end on one of the hoop bolts that holds the concrete panels of the silo together and bent the other end around the silo. Two people are needed to get a good enough bend in the pipe and that it probably only works for a single piece hoop. Thomas notes, "You cannot get any real bend in the ends of the pipe so two pieces stuck together leaves a flat part on top of the hoop house, which is far from ideal in a snowy climate."

Another Way to Bend Your Own

Kevin Loth, who is contractor as well as a farmer, has fabricated his family's 20' x 200' Quonset-style high tunnels near Lincoln, Nebraska. The Loths have two heated greenhouses and two year round high tunnels. By bending his own bows, he was able to get twice as much ground under cover than if he purchased kits. His calculation included what he paid a helper but not his own time. He said if you don't drill the bows, you could probably bend them in a day, though set up might take a couple of days.

With a borrowed pipe bender, he made bows out of the 15 gauge metal pipe used as a chain-link fence top rail. He saved considerably on the pipe by purchasing it by the bundle of 91 pipes. Because the pipe comes in 21' lengths, he had to swedge together one and a half lengths for each bow. While a swedging tool can be expensive, often when you buy fencing steel, one end comes already swedged.

His finished tunnels are Quonset-shaped, 10' high at the peak. Their bows are 4' on center, and they have two purlins but no trusses.

Kevin has attached the purlins and bows in several ways. Holes should be drilled prior to bending the bows. For the less technically adept, purlin clamp connectors (available from greenhouse suppliers) or pipe clamps (from plumbing supply outfits) preclude the need to drill holes for the bolts attaching the purlins. Getting these holes to line up properly can be difficult. Moreover, the very act of drilling holes weakens the steel.

While the purlin connectors are aluminum, Kevin dismisses concern about mixing metals as the tunnel's steel is galvanized. He thinks this is less of an issue than drilling holes as that action exposes ungalvanized steel and weakens the structural pieces. Also he noted that the ends of the bows are in contact with corrosive cement and soil acids.

Covering a High Tunnel

Farmers employ several methods for getting the unwieldy expanse of polyethylene film over the top of large hoop house structures and evenly attached. The size of your crew helps determine which methods are most feasible. The most important rule of thumb is never attempt to cover a tunnel on a windy day.

Covering a large (i.e., 30' x 96') high tunnel with a single layer of poly should take four or five people two or three hours. There is a learning curve so the first few times may take longer.

Method A: Pull over the end.

For this method, four or five people and a center-folded roll of polyethylene are required. (You can order your polyethylene folded in several ways.)

The first step is unrolling the plastic. To do this, set up a pair of cinderblocks a few feet further apart than the length of the roll of polyethylene. For a 12' tube, set the blocks about 14' apart. Then put a pipe in the tube. Make cardboard washers about 1' square to put on the ends of the pipe. The washers serve to protect the ends of the rolled up polyethylene from abrasion against the cinderblocks when you unroll it. This set up should allow the plastic to freely unroll.

The next step, getting the plastic over the tunnel, requires five people. One person is stationed on a ladder at a gable end of the high tunnel. Wearing a hooded sweatshirt is recommended to avoid plastic rubbing and to counteract the static electric generated by moving the plastic film over head. The center of the end of the poly is passed to the person on the ladder. The film unrolls as it is pulled up the ladder. Two people on the ground hold the corners and walk along side the tunnel as the plastic is unfurled. Meanwhile the person on the ladder does a sort of butterfly swimming

stroke, bringing the plastic overhead so that it clears the peak without getting caught.

The two people walking along the sides can have an exceedingly long way to pull the plastic. When they reach the middle of a long tunnel, two more people standing at the original gable end should assist pulling the plastic along. These additional people also help keep the plastic from becoming a sail if a sudden gust of wind comes along.

After the whole tunnel has been covered, it's time to even out the plastic. The selva edge must be even for the entire length of the tunnel and should be 12" or longer. You don't want the edge to run out!

If you are putting a second covering on, just tack it on the first layer using just a couple strategically placed poly fasteners (i.e., wiggle wire) and repeat the process with the second covering. Otherwise, proceed to the next step.

Once you are satisfied that the plastic is even on the edge, temporarily secure the plastic in place at three or four points on each side. The most common method for securing the plastic is wiggle wire inserted into a U channel. An alternative assembly is homemade—wood attached with drywall screws every 6" to 8".

Now you are ready to fully secure the single or double layer of plastic. The person on the ladder inserts wiggle wire from the top down on one of the gable ends. Next the plastic film at the other gable end should be pulled and that plastic "tacked" down. Once one gable-end plastic is permanently attached and the other gable end has been "tacked" in place (with a short wiggle wire), one side can be attached for a distance of about three bows. Remember to keep a constant selva edge (waste) edge. Another person (or two) starts on the opposite side of the first group and both groups attach side

plastic down to the end and finish the gable end. The reason for the staggered start and attachment is to avoid see-sawing the plastic side to side. The lead attachers must always keep the selva edge the same while the other side pulls the plastic to match.

Getting all of the wrinkles out is not important if you are going to inflate. It is important not to pull the poly film so tight that the wiggle wire in the U channel perforates the new plastic.

A variation on the pull-over-the-end method of covering a high tunnel is used by the Kilpatrick family. They set up the plastic on scaffolding at one end of the tunnel as described above. "Make sure the scaffolding is above the peak of the structure. While one person pulls the plastic down the length of the high tunnel, the others assist from the ground." Philip and Michael Kilpatrick have found that for work on the purlins, scaffolding mounted on a cart is far more convenient than using a ladder.

Method B: Ridge-roll.

This is one of the two ways that the Blomgrens cover their tunnels. (The other way is described in Method C.) Both methods involve climbing up the high tunnel and thus entail danger. Use these methods at your own risk.

Covering a high tunnel with a lean crew (four people) necessitates a different method. Once again, make sure to obtain greenhouse plastic with its fold down the center so it will unfurl properly.

In this technique two people carry the entire roll of poly up to the top of the high tunnel. A bucket loader is handy for this purpose. Before climbing up, they insert a pipe into the cardboard tube to assist in unrolling it. With the roll sitting on the top purlin, they temporarily fasten it on the gable end of the tunnel. Then they proceed to walk it down the tunnel, making use

of the side purlins, walking the roll along as they go. By the time the pair has walked halfway down the tunnel, the plastic will have begun unfurling, with half falling down one side and half down the other. (This unrolling procedure will go much more quickly if the high tunnel is designed so that the ridge purlin is situated on top of the bow. This is an atypical purlin placement and is only advisable for tunnels that will never be covered with a double, inflated layer of poly.)

Meanwhile the two other people, who are on the ground, are starting to tentatively connect the poly to the hip board just above the roll up sides.

After the plastic has been unrolled along the entire length of the tunnel, the two people who have been walking the ridge with the roll of poly temporarily connect the poly with wiggle wire at the top of the second gable end. They then climb down and join the two folks on the ground. With two people on each side of the tunnel, they square up the plastic, and then begin attaching the plastic along the top of the roll up sides. With the two teams working on opposite sides of the tunnel, they start at one end, and work toward the other end.

They then finish the gable ends, taking up the slack and smoothing out wrinkles, before permanently attaching it there. They trim off the excess plastic at the gable ends so it doesn't flap in the wind. To complete the covering, the roll up sides must be attached.

Method C: Over the side.

Like the previous method, this covering procedure used by the Blomgrens has safety and liability issues. As an alternative to climbing over the tunnel frame, Steve Moore suggests attaching grommets to the plastic and using ropes to pull it over the structure.

For a big tunnel (30' x 96' or 150'), at least eight people are needed for this method. Start by unrolling the plastic (without unfolding it) along the side of the high tunnel. If there is a risk of the slightest wind, it is best to be on the windward side of the tunnel.

After the plastic has been unrolled, people station themselves at regular intervals along the tunnel. They each take hold of what will become the far edge of the poly. Pulling this edge, they climb up and over the tunnel. With enough people, the weight of the poly is distributed and not burdensome to anyone.

Once the plastic is over the top of the structure, it is squared up, and then temporarily fastened to the gable ends. They then proceed as in the above description, with teams starting from opposite sides of one end and both working toward the far end.

There is an alternative to climbing up and over the greenhouse. Ropes may be attached to the plastic along its side. Clips available from greenhouse suppliers can be used to secure the rope to the plastic. Alternatively, wrap tennis balls in the plastic and use them to help fasten the rope. Toss the ropes over the tunnel structure and, once on the other side, pull the plastic over.

Tips for Attaching the Plastic

Single poly can be difficult to keep on a structure because there is no tension from an inflation fan to reduce flapping. Steve Moore has used wide poly strapping placed between every other bow and attached to the baseboard to keep the cover in place. This increases the longevity of the plastic film, and also reduces a farmer's worry about losing the plastic on the tunnels (and sleep) on windy nights.

If you choose to use wooden batten boards to fasten the plastic to the hip board, you would be wise to use a pair of batten boards one above the other with the plastic outside of the top one and behind the bottom one. This more effectively locks the poly in place. (See diagram below.)

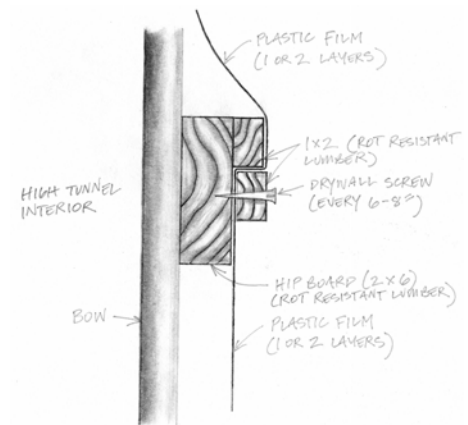

After you have to undo rusty screws or other failing attachments to remove old poly, you will probably come to believe that wiggle wire is a bargain at a \$1 per foot. When attaching new poly with wiggle wire, don't pull the poly too tight (or over inflate). The wiggle wire will actually cut perforations (corresponding to the wiggle wire) in the new cover if there is too much tension. This applies to double layers of poly, too.

When attaching plastic to battens (thin boards less than 1/2" x 1-1/2"), use double headed nails—rather than regular nails—for easier removal. Galvanized screws are another option.

Getting the Right Pressure on Your Inflation

Correct pressure ensures a balance between over and under inflation. By providing sufficient tightness of the plastic, flapping is minimized. If the plastic is stretched too tightly, light transmission is reduced. Simply put, correct pressure increases the life of the plastic and its ability to transmit light.

A manometer is an instrument used to measure the pressure of a gas. For high tunnels with a double poly layer, it is useful for determining the proper inflation pressure. Steve Moore makes his own homemade manometer using this simple procedure.

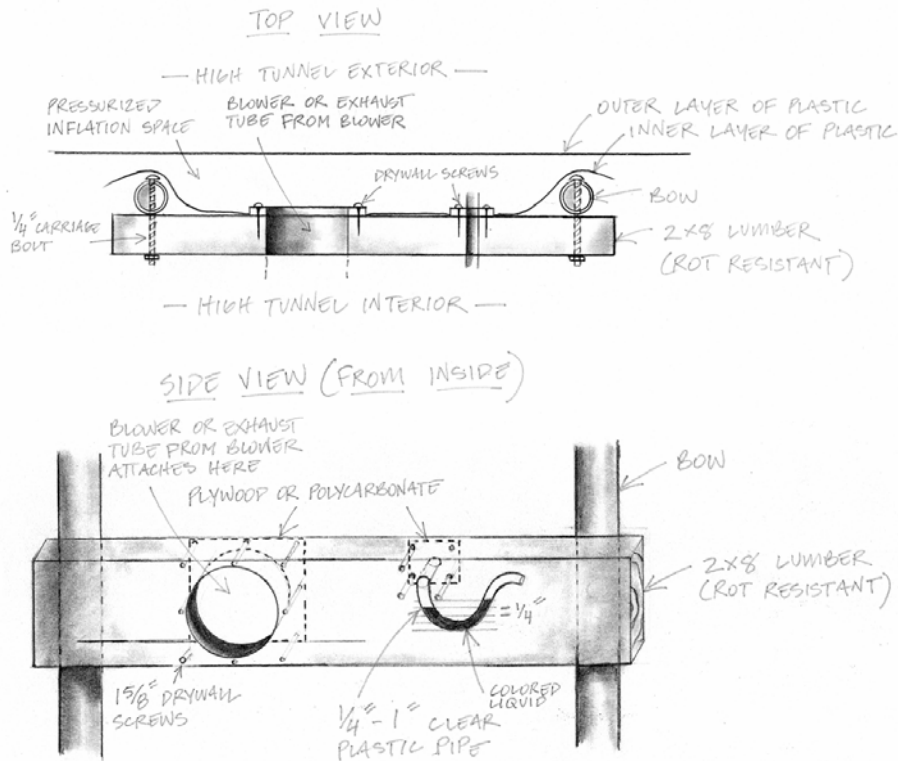

On the inside of the tunnel, attach a 2" x 8" (or wider) board with carriage bolts to two of the bows at a 4' to 6' height. (This board can be used to mount the inflation fan as well.) After covering the high tunnel with the first layer of poly, a 4" to 6" square piece of polycarbonate is attached with drywall screws to the wood before the tunnel is covered with a second layer of poly.

From the interior of the tunnel, drill a hole through the wood, the inside layer of plastic and the small piece of rigid material. From the inside, push a clear flexible plastic tube (available by the foot at most hardware store) into the wood, allowing the tube free access to the air between the layers. The tube's internal diameter can be from 3/4" to 1". Caulk around the tube so that it is airtight to prevent leaks.

Let the tube form a "U" with one of the top legs of the U going through the wood. Attach the other top of the U tube to the board and fill the bottom of the U with a colored liquid (blue washer fluid or colored water). Mark level horizontal lines 1/4 of an inch apart on the board next to the U portion of the clear tube. If the interior air level of the U is 1/4 inch higher than the inflation side of the U, then the pressure is about right. The liquid level on the side of the U that is attached to the board should be 1/4" lower than the side of the U that is open to the inside of the tunnel.

Adjust the pressure by using a damper on the intake of the inflation fan. You can make a damper with a flat piece of metal, like an old can lid (taped to keep from cutting yourself). Insert a screw through the top edge of the metal lid. Attach it tightly enough to the intake of the inflation fan that it will stay in place at various degrees of opening.

Steve has used solar power to run the inflation fan and his monitoring equipment.